

Example 3) From the given circuit

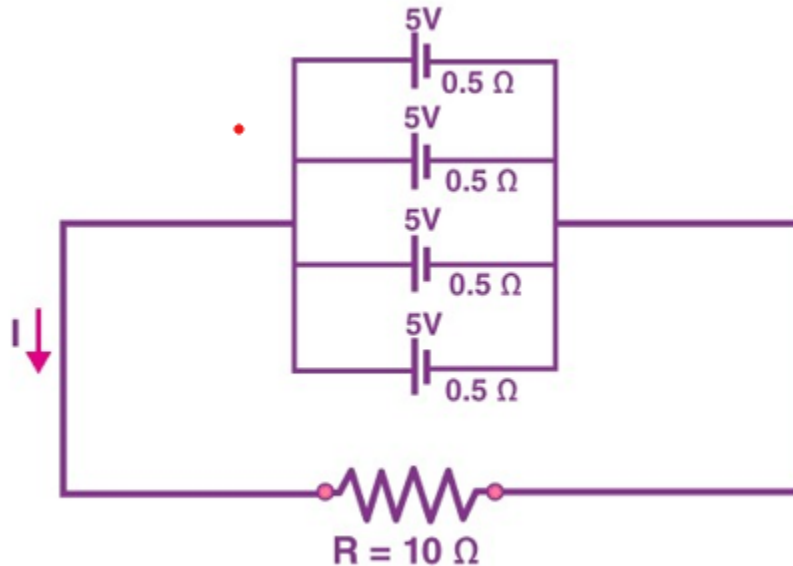

Find

- (i) **Equivalent EMF**
- (ii) **Equivalent internal resistance**
- (iii) **Total current**
- (iv) **Potential difference across each cell**
- (v) **Current from each cell**

Solution:

(i) There are four paths through the circuit. The potential difference across each path is 5V. This will be equal to the EMF of each cell. This means that the total EMF provided by the combination is also 5 Volts.

(ii) Since there are 4 cells with internal resistance 0.5Ω connected in parallel. The equivalent internal resistance is given by the formula

$$\frac{1}{r_{eq}} = \frac{1}{r_1} + \frac{1}{r_2} + \frac{1}{r_3} + \frac{1}{r_4}$$

$$\frac{1}{r_{eq}} = \frac{1}{0.5} + \frac{1}{0.5} + \frac{1}{0.5} + \frac{1}{0.5}$$

$$\frac{1}{r_{eq}} = 4$$

$$r_{eq} = \frac{1}{4} = 0.25 \Omega$$

(or) $r_{eq} = \frac{r}{n} = \frac{0.5}{4} = 0.125 \Omega$ (iii)

Total current, $I = \frac{\epsilon}{R + r/n}$

$$I = \frac{5}{10 + 0.125}$$

$$= 5 / 10.125$$

$$= 0.5 \text{ A}$$

(iv) Potential difference $V = IR = 0.5 \times 10 = 5 \text{ V}$

(v) Current from each cell

$$I' = I/n$$

$$= 0.5/4 = 0.125 \text{ A}$$