

7.10.1 Theorem of parallel axes

This theorem is applicable to a body of any shape. It allows to find the moment of inertia of a body about any axis, given the moment of inertia of the body about a parallel axis through the centre of mass of the body. We shall only state this theorem and not give its proof. We shall, however, apply it to a few simple situations which will be enough to convince us about the usefulness of the theorem. The theorem may be stated as follows:

The moment of inertia of a body about any axis is equal to the sum of the moment of inertia of the body about a parallel axis passing through its centre of mass and the product of its mass and the square of the distance between the two parallel axes. As shown in the Fig. 7.31, z and z' are two parallel axes, separated by a distance a . The z -axis passes through the centre of mass O of the rigid body. Then according to the theorem of parallel axes

$$I_{z'} = I_z + Ma^2 \tag{7.37}$$

where I_z and $I_{z'}$ are the moments of inertia of the body about the z and z' axes respectively, M is the total mass of the body and a is the perpendicular distance between the two parallel axes.

► **Example 7.11** What is the moment of inertia of a rod of mass M , length l about an axis perpendicular to it through one end?

Answer For the rod of mass M and length l , $I = Ml^2/12$. Using the parallel axes theorem, $I' = I + Ma^2$ with $a = l/2$ we get,

$$I' = M \frac{l^2}{12} + M \left(\frac{l}{2} \right)^2 = \frac{Ml^2}{3}$$

We can check this independently since I is half the moment of inertia of a rod of mass $2M$ and length $2l$ about its midpoint,

$$I' = 2M \cdot \frac{4l^2}{12} \times \frac{1}{2} = \frac{Ml^2}{3}$$

► **Example 7.12** What is the moment of inertia of a ring about a tangent to the circle of the ring?

Answer The tangent to the ring in the plane of the ring is parallel to one of the diameters of the ring.

The distance between these two parallel axes is R , the radius of the ring. Using the parallel axes theorem,

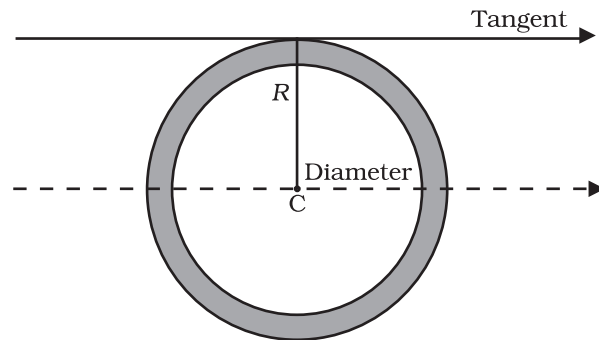

Fig. 7.32

$$I_{\text{tangent}} = I_{\text{dia}} + MR^2 = \frac{MR^2}{2} + MR^2 = \frac{3}{2} MR^2$$

7.11 KINEMATICS OF ROTATIONAL MOTION ABOUT A FIXED AXIS

We have already indicated the analogy between rotational motion and translational motion. For example, the angular velocity ω plays the same role in rotation as the linear velocity \mathbf{v} in translation. We wish to take this analogy further. In doing so we shall restrict the discussion only to rotation about fixed axis. This case of motion involves only one degree of freedom, i.e., needs only one independent variable to describe the motion. This in translation corresponds to linear motion. This section is limited only to kinematics. We shall turn to dynamics in later sections.

We recall that for specifying the angular displacement of the rotating body we take any particle like P (Fig.7.33) of the body. Its angular displacement θ in the plane it moves is the angular displacement of the whole body; θ is measured from a fixed direction in the plane of motion of P, which we take to be the x' -axis, chosen parallel to the x -axis. Note, as shown, the axis of rotation is the z -axis and the plane of the motion of the particle is the $x - y$ plane. Fig. 7.33 also shows θ_0 , the angular displacement at $t = 0$.

We also recall that the angular velocity is the time rate of change of angular displacement, $\omega = d\theta/dt$. Note since the axis of rotation is fixed,

there is no need to treat angular velocity as a vector. Further, the angular acceleration, $\alpha = d\omega/dt$.

The kinematical quantities in rotational motion, angular displacement (θ), angular velocity (ω) and angular acceleration (α) respectively are analogous to kinematic quantities in linear motion, displacement (x), velocity (v) and acceleration (a). We know the kinematical equations of linear motion with uniform (i.e. constant) acceleration:

$$v = v_0 + at \quad (a)$$

$$x = x_0 + v_0t + \frac{1}{2}at^2 \quad (b)$$

$$v^2 = v_0^2 + 2ax \quad (c)$$

where x_0 = initial displacement and v_0 = initial velocity. The word 'initial' refers to values of the quantities at $t = 0$

The corresponding kinematic equations for rotational motion with uniform angular acceleration are:

$$\omega = \omega_0 + \alpha t \quad (7.38)$$

$$\theta = \theta_0 + \omega_0 t + \frac{1}{2}\alpha t^2 \quad (7.39)$$

$$\text{and } \omega^2 = \omega_0^2 + 2\alpha(\theta - \theta_0) \quad (7.40)$$

where θ_0 = initial angular displacement of the rotating body, and ω_0 = initial angular velocity of the body.

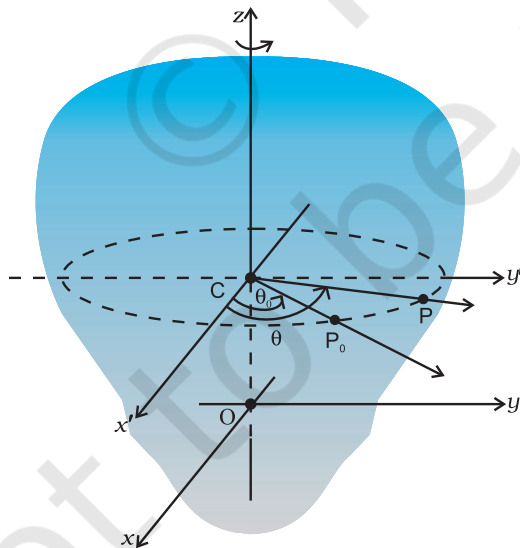

Fig. 7.33 Specifying the angular position of a rigid body.

► **Example 7.13** Obtain Eq. (7.38) from first principles.

Answer The angular acceleration is uniform, hence

$$\frac{d\omega}{dt} = \alpha = \text{constant} \quad (i)$$

Integrating this equation,

$$\omega = \int \alpha dt + c$$

$$= \alpha t + c \quad (\text{as } \alpha \text{ is constant})$$

At $t = 0$, $\omega = \omega_0$ (given)

From (i) we get at $t = 0$, $\omega = c = \omega_0$

Thus, $\omega = \alpha t + \omega_0$ as required.

With the definition of $\omega = d\theta/dt$ we may integrate Eq. (7.38) to get Eq. (7.39). This derivation and the derivation of Eq. (7.40) is left as an exercise.

► **Example 7.14** The angular speed of a motor wheel is increased from 1200 rpm to 3120 rpm in 16 seconds. (i) What is its angular acceleration, assuming the acceleration to be uniform? (ii) How many revolutions does the engine make during this time?

Answer

(i) We shall use $\omega = \omega_0 + \alpha t$

$$\omega_0 = \text{initial angular speed in rad/s}$$

$$= 2\pi \times \text{angular speed in rev/s}$$

$$= \frac{2\pi \times \text{angular speed in rev/min}}{60 \text{ s/min}}$$

$$= \frac{2\pi \times 1200}{60} \text{ rad/s}$$

$$= 40\pi \text{ rad/s}$$

Similarly $\omega =$ final angular speed in rad/s

$$= \frac{2\pi \times 3120}{60} \text{ rad/s}$$

$$= 2\pi \times 52 \text{ rad/s}$$

$$= 104\pi \text{ rad/s}$$

∴ Angular acceleration

$$\alpha = \frac{\omega - \omega_0}{t} = 4\pi \text{ rad/s}^2$$

The angular acceleration of the engine = $4\pi \text{ rad/s}^2$

(ii) The angular displacement in time t is given by

$$\begin{aligned} \theta &= \omega_0 t + \frac{1}{2} \alpha t^2 \\ &= (40\pi \times 16 + \frac{1}{2} \times 4\pi \times 16^2) \text{ rad} \\ &= (640\pi + 512\pi) \text{ rad} \\ &= 1152\pi \text{ rad} \end{aligned}$$

Number of revolutions = $\frac{1152\pi}{2\pi} = 576$ ◀

7.12 DYNAMICS OF ROTATIONAL MOTION ABOUT A FIXED AXIS

Table 7.2 lists quantities associated with linear motion and their analogues in rotational motion. We have already compared kinematics of the two motions. Also, we know that in rotational motion moment of inertia and torque play the same role as mass and force respectively in linear motion. Given this we should be able to guess what the other analogues indicated in the table are. For example, we know that in linear motion, work done is given by $F dx$, in rotational motion about a fixed axis it should be $\tau d\theta$, since we already know the correspondence $dx \rightarrow d\theta$ and $F \rightarrow \tau$. It is, however, necessary that these correspondences are established on sound dynamical considerations. This is what we now turn to.

Before we begin, we note a **simplification that arises in the case of rotational motion about a fixed axis**. Since the axis is fixed, only those components of torques, which are along the direction of the fixed axis need to be considered in our discussion. Only these components can cause the body to rotate about the axis. A component of the torque perpendicular to the axis of rotation will tend to turn the axis from its position. We specifically assume that there will arise necessary forces of constraint to cancel the effect of the perpendicular components of the (external) torques, so that the fixed position of the axis will be maintained. The perpendicular components of the torques, therefore need not be taken into account. This means that for our calculation of torques on a rigid body:

- (1) We need to consider only those forces that lie in planes perpendicular to the axis. Forces which are parallel to the axis will give torques perpendicular to the axis and need not be taken into account.
- (2) We need to consider only those components of the position vectors which are perpendicular to the axis. Components of position vectors along the axis will result in torques perpendicular to the axis and need not be taken into account.

Work done by a torque

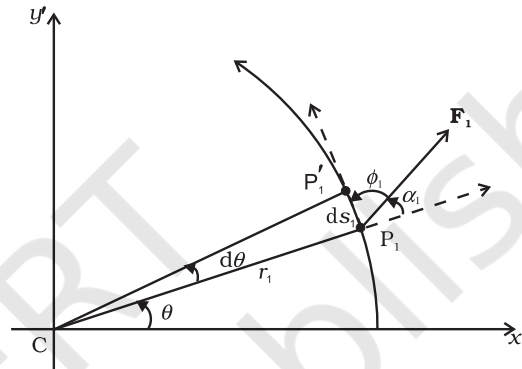

Fig. 7.34 Work done by a force F_1 acting on a particle of a body rotating about a fixed axis; the particle describes a circular path with centre C on the axis; arc P_1P_1' (ds_1) gives the displacement of the particle.

Figure 7.34 shows a cross-section of a rigid body rotating about a fixed axis, which is taken as the z-axis (perpendicular to the plane of the page; see Fig. 7.33). As said above we need to consider only those forces which lie in planes perpendicular to the axis. Let F_1 be one such typical force acting as shown on a particle of the body at point P_1 with its line of action in a plane perpendicular to the axis. For convenience we call this to be the $x'-y'$ plane (coincident with the plane of the page). The particle at P_1 describes a circular path of radius r_1 with centre C on the axis; $CP_1 = r_1$.

In time Δt , the point moves to the position P_1' . The displacement of the particle ds_1 , therefore, has magnitude $ds_1 = r_1 d\theta$ and direction tangential at P_1 to the circular path as shown. Here $d\theta$ is the angular displacement of the particle, $d\theta = \angle P_1CP_1'$. The work done by the force on the particle is

$$dW_1 = \mathbf{F}_1 \cdot d\mathbf{s}_1 = F_1 ds_1 \cos \phi_1 = F_1 (r_1 d\theta) \sin \alpha_1$$

where ϕ_1 is the angle between F_1 and the tangent

Table 7.2 Comparison of Translational and Rotational Motion

Linear Motion	Rotational Motion about a Fixed Axis
1 Displacement x	Angular displacement θ
2 Velocity $v = dx/dt$	Angular velocity $\omega = d\theta/dt$
3 Acceleration $a = dv/dt$	Angular acceleration $\alpha = d\omega/dt$
4 Mass M	Moment of inertia I
5 Force $F = Ma$	Torque $\tau = I\alpha$
6 Work $dW = F ds$	Work $W = \tau d\theta$
7 Kinetic energy $K = Mv^2/2$	Kinetic energy $K = I\omega^2/2$
8 Power $P = Fv$	Power $P = \tau\omega$
9 Linear momentum $p = Mv$	Angular momentum $L = I\omega$

at P_1 and α_1 is the angle between \mathbf{F}_1 and the radius vector \mathbf{OP}_1 ; $\phi_1 + \alpha_1 = 90^\circ$.

The torque due to \mathbf{F}_1 about the origin is $\mathbf{OP}_1 \times \mathbf{F}_1$. Now $\mathbf{OP}_1 = \mathbf{OC} + \mathbf{CP}_1$. [Refer to Fig. 7.17(b).] Since \mathbf{OC} is along the axis, the torque resulting from it is excluded from our consideration. The effective torque due to \mathbf{F}_1 is $\boldsymbol{\tau}_1 = \mathbf{CP}_1 \times \mathbf{F}_1$; it is directed along the axis of rotation and has a magnitude $\tau_1 = r_1 F_1 \sin\alpha$. Therefore,

$$dW_1 = \tau_1 d\theta$$

If there are more than one forces acting on the body, the work done by all of them can be added to give the total work done on the body. Denoting the magnitudes of the torques due to the different forces as τ_1, τ_2, \dots etc,

$$dW = (\tau_1 + \tau_2 + \dots) d\theta$$

Remember, the forces giving rise to the torques act on different particles, but the angular displacement $d\theta$ is the same for all particles. Since all the torques considered are parallel to the fixed axis, the magnitude τ of the total torque is just the algebraic sum of the magnitudes of the torques, i.e., $\tau = \tau_1 + \tau_2 + \dots$. We, therefore, have

$$dW = \tau d\theta \quad (7.41)$$

This expression gives the work done by the total (external) torque τ which acts on the body rotating about a fixed axis. Its similarity with the corresponding expression

$$dW = F ds$$

for linear (translational) motion is obvious.

Dividing both sides of Eq. (7.41) by dt gives

$$P = \frac{dW}{dt} = \tau \frac{d\theta}{dt} = \tau\omega$$

$$\text{or } P = \tau\omega \quad (7.42)$$

This is the instantaneous power. Compare this expression for power in the case of rotational motion about a fixed axis with that of power in the case of linear motion,

$$P = Fv$$

In a perfectly rigid body there is no internal motion. The work done by external torques is therefore, not dissipated and goes on to increase the kinetic energy of the body. The rate at which work is done on the body is given by Eq. (7.42). This is to be equated to the rate at which kinetic energy increases. The rate of increase of kinetic energy is

$$\frac{d}{dt} \left(\frac{I\omega^2}{2} \right) = I \frac{(2\omega) d\omega}{2 dt}$$

We assume that the moment of inertia does not change with time. This means that the mass of the body does not change, the body remains rigid and also the axis does not change its position with respect to the body.

Since $\alpha = d\omega/dt$, we get

$$\frac{d}{dt} \left(\frac{I\omega^2}{2} \right) = I\omega\alpha$$

Equating rates of work done and of increase in kinetic energy,

$$\tau\omega = I\omega\alpha$$

$$\tau = I\alpha \tag{7.43}$$

Eq. (7.43) is similar to Newton's second law for linear motion expressed symbolically as

$$F = ma$$

Just as force produces acceleration, torque produces angular acceleration in a body. The angular acceleration is directly proportional to the applied torque and is inversely proportional to the moment of inertia of the body. In this respect, Eq.(7.43) can be called Newton's second law for rotational motion about a fixed axis.

► **Example 7.15** A cord of negligible mass is wound round the rim of a fly wheel of mass 20 kg and radius 20 cm. A steady pull of 25 N is applied on the cord as shown in Fig. 7.35. The flywheel is mounted on a horizontal axle with frictionless bearings.

- Compute the angular acceleration of the wheel.
- Find the work done by the pull, when 2m of the cord is unwound.
- Find also the kinetic energy of the wheel at this point. Assume that the wheel starts from rest.
- Compare answers to parts (b) and (c).

Answer

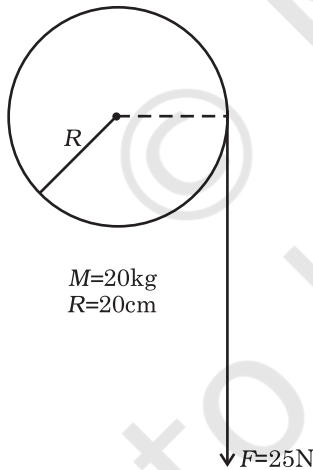

Fig. 7.35

- (a) We use $I\alpha = \tau$
 the torque $\tau = FR$
 $= 25 \times 0.20 \text{ Nm (as } R = 0.20\text{m)}$
 $= 5.0 \text{ Nm}$

$I =$ Moment of inertia of flywheel about its

$$\text{axis} = \frac{MR^2}{2}$$

$$= \frac{20.0 \times (0.2)^2}{2} = 0.4 \text{ kg m}^2$$

$\alpha =$ angular acceleration
 $= 5.0 \text{ N m} / 0.4 \text{ kg m}^2 = 12.5 \text{ s}^{-2}$

- (b) Work done by the pull unwinding 2m of the cord
 $= 25 \text{ N} \times 2\text{m} = 50 \text{ J}$
- (c) Let ω be the final angular velocity. The

kinetic energy gained $= \frac{1}{2}I\omega^2$,

since the wheel starts from rest. Now,

$$\omega^2 = \omega_0^2 + 2\alpha\theta, \quad \omega_0 = 0$$

The angular displacement $\theta =$ length of unwound string / radius of wheel
 $= 2\text{m} / 0.2 \text{ m} = 10 \text{ rad}$

$$\omega^2 = 2 \times 12.5 \times 10.0 = 250 \text{ (rad/s)}^2$$

\therefore K.E. gained $= \frac{1}{2} \times 0.4 \times 250 = 50 \text{ J}$

- (d) The answers are the same, i.e. the kinetic energy gained by the wheel = work done by the force. There is no loss of energy due to friction. ◀

7.13 ANGULAR MOMENTUM IN CASE OF ROTATION ABOUT A FIXED AXIS

We have studied in section 7.7, the angular momentum of a system of particles. We already know from there that the time rate of total angular momentum of a system of particles about a point is equal to the total external torque on the system taken about the same point. When the total external torque is zero, the total angular momentum of the system is conserved.

We now wish to study the angular momentum in the special case of rotation about a fixed axis. The general expression for the total angular momentum of the system of n particles is

$$\mathbf{L} = \sum_{i=1}^n \mathbf{r}_i \times \mathbf{p}_i \tag{7.25b}$$

We first consider the angular momentum of a typical particle of the rotating rigid body. We then sum up the contributions of individual particles to get \mathbf{L} of the whole body.

For a typical particle $l = \mathbf{r} \times \mathbf{p}$. As seen in the last section $\mathbf{r} = \mathbf{OP} = \mathbf{OC} + \mathbf{CP}$ [Fig. 7.17(b)]. With