

verified experimentally at ordinary temperatures.

► **Example 13.8** A cylinder of fixed capacity 44.8 litres contains helium gas at standard temperature and pressure. What is the amount of heat needed to raise the temperature of the gas in the cylinder by $15.0\text{ }^\circ\text{C}$? ($R = 8.31\text{ J mol}^{-1}\text{ K}^{-1}$).

Answer Using the gas law $PV = \mu RT$, you can easily show that 1 mol of any (ideal) gas at standard temperature (273 K) and pressure (1 atm = 1.01×10^5 Pa) occupies a volume of 22.4 litres. This universal volume is called molar volume. Thus the cylinder in this example contains 2 mol of helium. Further, since helium is monatomic, its predicted (and observed) molar specific heat at constant volume, $C_v = (3/2)R$, and molar specific heat at constant pressure, $C_p = (3/2)R + R = (5/2)R$. Since the volume of the cylinder is fixed, the heat required is determined by C_v . Therefore,

$$\begin{aligned} \text{Heat required} &= \text{no. of moles} \times \text{molar specific heat} \times \text{rise in temperature} \\ &= 2 \times 1.5 R \times 15.0 = 45 R \\ &= 45 \times 8.31 = 374 \text{ J.} \end{aligned}$$

13.6.4 Specific Heat Capacity of Solids

We can use the law of equipartition of energy to determine specific heats of solids. Consider a solid of N atoms, each vibrating about its mean position. An oscillation in one dimension has average energy of $\frac{1}{2} k_B T = k_B T$. In three dimensions, the average energy is $3 k_B T$. For a mole of solid, $N = N_A$, and the total energy is

$$U = 3 k_B T N_A = 3 RT$$

Now at constant pressure $\Delta Q = \Delta U + P\Delta V = \Delta U$, since for a solid ΔV is negligible. Hence,

$$C = \frac{Q}{T} = \frac{U}{T} = 3R \quad (13.37)$$

Table 13.3 Specific Heat Capacity of some solids at room temperature and atmospheric pressure

Substance	Specific heat ($\text{J kg}^{-1}\text{ K}^{-1}$)	Molar specific Heat ($\text{J mol}^{-1}\text{ K}^{-1}$)
Aluminium	900.0	24.4
Carbon	506.5	6.1
Copper	386.4	24.5
Lead	127.7	26.5
Silver	236.1	25.5
Tungsten	134.4	24.9

As Table 13.3 shows the prediction generally agrees with experimental values at ordinary temperature (Carbon is an exception).

13.6.5 Specific Heat Capacity of Water

We treat water like a solid. For each atom average energy is $3k_B T$. Water molecule has three atoms, two hydrogen and one oxygen. So it has

$$U = 3 \times 3 k_B T N_A = 9 RT$$

$$\text{and } C = \Delta Q / \Delta T = \Delta U / \Delta T = 9R.$$

This is the value observed and the agreement is very good. In the calorie, gram, degree units, water is defined to have unit specific heat. As 1 calorie = 4.179 joules and one mole of water is 18 grams, the heat capacity per mole is $\sim 75\text{ J mol}^{-1}\text{ K}^{-1} \sim 9R$. However with more complex molecules like alcohol or acetone the arguments, based on degrees of freedom, become more complicated.

Lastly, we should note an important aspect of the predictions of specific heats, based on the classical law of equipartition of energy. The predicted specific heats are independent of temperature. As we go to low temperatures, however, there is a marked departure from this prediction. Specific heats of all substances approach zero as $T \rightarrow 0$. This is related to the fact that degrees of freedom get frozen and ineffective at low temperatures. According to classical physics degrees of freedom must remain unchanged at all times. The behaviour of specific heats at low temperatures shows the inadequacy of classical physics and can be explained only by invoking quantum considerations, as was first shown by Einstein. Quantum mechanics requires a minimum, nonzero amount of energy before a degree of freedom comes into play. This is also the reason why vibrational degrees of freedom come into play only in some cases.

13.7 MEAN FREE PATH

Molecules in a gas have rather large speeds of the order of the speed of sound. Yet a gas leaking from a cylinder in a kitchen takes considerable time to diffuse to the other corners of the room. The top of a cloud of smoke holds together for hours. This happens because molecules in a gas have a finite though small size, so they are bound to undergo collisions. As a result, they cannot

Seeing is Believing

Can one see atoms rushing about. Almost but not quite. One can see pollen grains of a flower being pushed around by molecules of water. The size of the grain is $\sim 10^{-5}$ m. In 1827, a Scottish botanist Robert Brown, while examining, under a microscope, pollen grains of a flower suspended in water noticed that they continuously moved about in a zigzag, random fashion.

Kinetic theory provides a simple explanation of the phenomenon. Any object suspended in water is continuously bombarded from all sides by the water molecules. Since the motion of molecules is random, the number of molecules hitting the object in any direction is about the same as the number hitting in the opposite direction. The small difference between these molecular hits is negligible compared to the total number of hits for an object of ordinary size, and we do not notice any movement of the object.

When the object is sufficiently small but still visible under a microscope, the difference in molecular hits from different directions is not altogether negligible, i.e. the impulses and the torques given to the suspended object through continuous bombardment by the molecules of the medium (water or some other fluid) do not exactly sum to zero. There is a net impulse and torque in this or that direction. The suspended object thus, moves about in a zigzag manner and tumbles about randomly. This motion called now 'Brownian motion' is a visible proof of molecular activity. In the last 50 years or so molecules have been seen by scanning tunneling and other special microscopes.

In 1987 Ahmed Zewail, an Egyptian scientist working in USA was able to observe not only the molecules but also their detailed interactions. He did this by illuminating them with flashes of laser light for very short durations, of the order of tens of femtoseconds and photographing them. (1 femtosecond = 10^{-15} s). One could study even the formation and breaking of chemical bonds. That is really seeing !

move straight unhindered; their paths keep getting incessantly deflected.

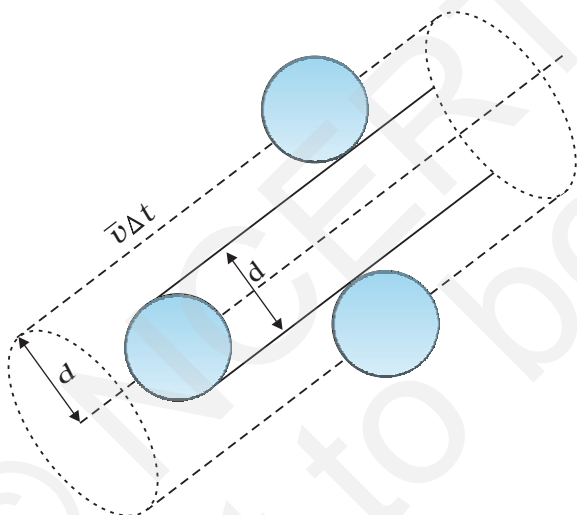

Fig. 13.7 The volume swept by a molecule in time Δt in which any molecule will collide with it.

Suppose the molecules of a gas are spheres of diameter d . Focus on a single molecule with the average speed $\langle v \rangle$. It will suffer collision with any molecule that comes within a distance d between the centres. In time Δt , it sweeps a volume $\pi d^2 \langle v \rangle \Delta t$ wherein any other molecule

will collide with it (see Fig. 13.7). If n is the number of molecules per unit volume, the molecule suffers $n\pi d^2 \langle v \rangle \Delta t$ collisions in time Δt . Thus the rate of collisions is $n\pi d^2 \langle v \rangle$ or the time between two successive collisions is on the average,

$$\tau = 1/(n\pi \langle v \rangle d^2) \quad (13.38)$$

The average distance between two successive collisions, called the mean free path l , is :

$$l = \langle v \rangle \tau = 1/(n\pi d^2) \quad (13.39)$$

In this derivation, we imagined the other molecules to be at rest. But actually all molecules are moving and the collision rate is determined by the average relative velocity of the molecules. Thus we need to replace $\langle v \rangle$ by $\langle v_r \rangle$ in Eq. (13.38). A more exact treatment gives

$$l = 1/\sqrt{2} n d^2 \quad (13.40)$$

Let us estimate l and τ for air molecules with average speeds $\langle v \rangle = (485\text{m/s})$. At STP

$$\begin{aligned} n &= \frac{0.02 \cdot 10^{23}}{22.4 \cdot 10^{-3}} \\ &= 2.7 \cdot 10^{25} \text{ m}^{-3}. \end{aligned}$$

Taking, $d = 2 \cdot 10^{-10}$ m,
 $\tau = 6.1 \cdot 10^{-10}$ s
and $l = 2.9 \cdot 10^{-7}$ m $\approx 1500d$ (13.41)

As expected, the mean free path given by Eq. (13.40) depends inversely on the number density and the size of the molecules. In a highly evacuated tube n is rather small and the mean free path can be as large as the length of the tube.

► **Example 13.9** Estimate the mean free path for a water molecule in water vapour at 373 K. Use information from Exercises 13.1 and Eq. (13.41) above.

Answer The d for water vapour is same as that of air. The number density is inversely proportional to absolute temperature.

$$\text{So } n = 2.7 \times 10^{25} \frac{273}{373} = 2 \times 10^{25} \text{ m}^{-3}$$

$$\text{Hence, mean free path } l = 4 \times 10^{-7} \text{ m} \quad \blacktriangleleft$$

Note that the mean free path is 100 times the interatomic distance $\sim 40 \text{ \AA} = 4 \times 10^{-9} \text{ m}$ calculated earlier. It is this large value of mean free path that leads to the typical gaseous behaviour. Gases can not be confined without a container.

Using, the kinetic theory of gases, the bulk measurable properties like viscosity, heat conductivity and diffusion can be related to the microscopic parameters like molecular size. It is through such relations that the molecular sizes were first estimated.

SUMMARY

1. The ideal gas equation connecting pressure (P), volume (V) and absolute temperature (T) is

$$PV = \mu RT = k_B NT$$

where μ is the number of moles and N is the number of molecules. R and k_B are universal constants.

$$R = 8.314 \text{ J mol}^{-1} \text{ K}^{-1}, \quad k_B = \frac{R}{N_A} = 1.38 \times 10^{-23} \text{ J K}^{-1}$$

Real gases satisfy the ideal gas equation only approximately, more so at low pressures and high temperatures.

2. Kinetic theory of an ideal gas gives the relation

$$P = \frac{1}{3} n m \overline{v^2}$$

where n is number density of molecules, m the mass of the molecule and $\overline{v^2}$ is the mean of squared speed. Combined with the ideal gas equation it yields a kinetic interpretation of temperature.

$$\frac{1}{2} m \overline{v^2} = \frac{3}{2} k_B T, \quad v_{rms} = \overline{v^2}^{1/2} = \sqrt{\frac{3k_B T}{m}}$$

This tells us that the temperature of a gas is a measure of the average kinetic energy of a molecule, *independent of the nature of the gas or molecule*. In a mixture of gases at a fixed temperature the heavier molecule has the lower average speed.

3. The translational kinetic energy

$$E = \frac{3}{2} k_B NT.$$

This leads to a relation

$$PV = \frac{2}{3} E$$

4. The law of equipartition of energy states that if a system is in equilibrium at absolute temperature T , the total energy is distributed equally in different energy modes of

absorption, the energy in each mode being equal to $\frac{1}{2} k_B T$. Each translational and rotational degree of freedom corresponds to one energy mode of absorption and has energy $\frac{1}{2} k_B T$. Each vibrational frequency has two modes of energy (kinetic and potential) with corresponding energy equal to

$$2 \times \frac{1}{2} k_B T = k_B T.$$

- Using the law of equipartition of energy, the molar specific heats of gases can be determined and the values are in agreement with the experimental values of specific heats of several gases. The agreement can be improved by including vibrational modes of motion.
- The mean free path l is the average distance covered by a molecule between two successive collisions :

$$\bar{l} = \frac{1}{\sqrt{2} n d^2}$$

where n is the number density and d the diameter of the molecule.

POINTS TO PONDER

- Pressure of a fluid is not only exerted on the wall. Pressure exists everywhere in a fluid. Any layer of gas inside the volume of a container is in equilibrium because the pressure is the same on both sides of the layer.
- We should not have an exaggerated idea of the intermolecular distance in a gas. At ordinary pressures and temperatures, this is only 10 times or so the interatomic distance in solids and liquids. What is different is the mean free path which in a gas is 100 times the interatomic distance and 1000 times the size of the molecule.
- The law of equipartition of energy is stated thus: the energy for each degree of freedom in thermal equilibrium is $\frac{1}{2} k_B T$. Each quadratic term in the total energy expression of a molecule is to be counted as a degree of freedom. Thus, each vibrational mode gives 2 (not 1) degrees of freedom (kinetic and potential energy modes), corresponding to the energy $2 \times \frac{1}{2} k_B T = k_B T$.
- Molecules of air in a room do not all fall and settle on the ground (due to gravity) because of their high speeds and incessant collisions. In equilibrium, there is a very slight increase in density at lower heights (like in the atmosphere). The effect is small since the potential energy (mgh) for ordinary heights is much less than the average kinetic energy $\frac{1}{2} mv^2$ of the molecules.
- $\langle v^2 \rangle$ is not always equal to $(\langle v \rangle)^2$. The average of a squared quantity is not necessarily the square of the average. Can you find examples for this statement.

EXERCISES

- Estimate the fraction of molecular volume to the actual volume occupied by oxygen gas at STP. Take the diameter of an oxygen molecule to be 3 Å.
- Molar volume is the volume occupied by 1 mol of any (ideal) gas at standard temperature and pressure (STP : 1 atmospheric pressure, 0 °C). Show that it is 22.4 litres.
- Figure 13.8 shows plot of PV/T versus P for 1.0010^{-3} kg of oxygen gas at two different temperatures.

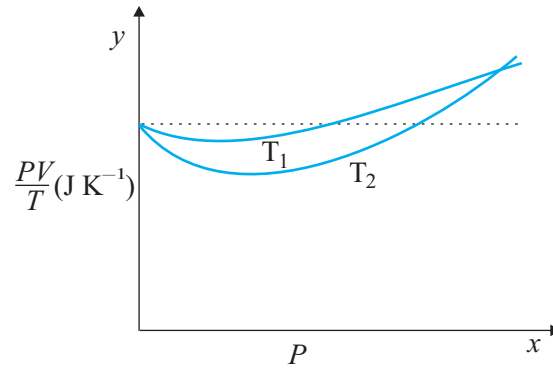

Fig. 13.8

- (a) What does the dotted plot signify?
 (b) Which is true: $T_1 > T_2$ or $T_1 < T_2$?
 (c) What is the value of PV/T where the curves meet on the y -axis?
 (d) If we obtained similar plots for 1.00×10^{-3} kg of hydrogen, would we get the same value of PV/T at the point where the curves meet on the y -axis? If not, what mass of hydrogen yields the same value of PV/T (for low pressure high temperature region of the plot)? (Molecular mass of $H_2 = 2.02$ u, of $O_2 = 32.0$ u, $R = 8.31 \text{ J mol}^{-1} \text{ K}^{-1}$.)

- 13.4** An oxygen cylinder of volume 30 litres has an initial gauge pressure of 15 atm and a temperature of 27°C . After some oxygen is withdrawn from the cylinder, the gauge pressure drops to 11 atm and its temperature drops to 17°C . Estimate the mass of oxygen taken out of the cylinder ($R = 8.31 \text{ J mol}^{-1} \text{ K}^{-1}$, molecular mass of $O_2 = 32$ u).
- 13.5** An air bubble of volume 1.0 cm^3 rises from the bottom of a lake 40 m deep at a temperature of 12°C . To what volume does it grow when it reaches the surface, which is at a temperature of 35°C ?
- 13.6** Estimate the total number of air molecules (inclusive of oxygen, nitrogen, water vapour and other constituents) in a room of capacity 25.0 m^3 at a temperature of 27°C and 1 atm pressure.
- 13.7** Estimate the average thermal energy of a helium atom at (i) room temperature (27°C), (ii) the temperature on the surface of the Sun (6000 K), (iii) the temperature of 10 million kelvin (the typical core temperature in the case of a star).
- 13.8** Three vessels of equal capacity have gases at the same temperature and pressure. The first vessel contains neon (monatomic), the second contains chlorine (diatomic), and the third contains uranium hexafluoride (polyatomic). Do the vessels contain equal number of respective molecules? Is the root mean square speed of molecules the same in the three cases? If not, in which case is v_{rms} the largest?
- 13.9** At what temperature is the root mean square speed of an atom in an argon gas cylinder equal to the rms speed of a helium gas atom at -20°C ? (atomic mass of Ar = 39.9 u, of He = 4.0 u).
- 13.10** Estimate the mean free path and collision frequency of a nitrogen molecule in a cylinder containing nitrogen at 2.0 atm and temperature 17°C . Take the radius of a nitrogen molecule to be roughly 1.0 \AA . Compare the collision time with the time the molecule moves freely between two successive collisions (Molecular mass of $N_2 = 28.0$ u).

Additional Exercises

13.11 A metre long narrow bore held horizontally (and closed at one end) contains a 76 cm long mercury thread, which traps a 15 cm column of air. What happens if the tube is held vertically with the open end at the bottom ?

13.12 From a certain apparatus, the diffusion rate of hydrogen has an average value of $28.7 \text{ cm}^3 \text{ s}^{-1}$. The diffusion of another gas under the same conditions is measured to have an average rate of $7.2 \text{ cm}^3 \text{ s}^{-1}$. Identify the gas.

[Hint : Use Graham's law of diffusion: $R_1/R_2 = (M_2/M_1)^{1/2}$, where R_1, R_2 are diffusion rates of gases 1 and 2, and M_1 and M_2 their respective molecular masses. The law is a simple consequence of kinetic theory.]

13.13 A gas in equilibrium has uniform density and pressure throughout its volume. This is strictly true only if there are no external influences. A gas column under gravity, for example, does not have uniform density (and pressure). As you might expect, its density decreases with height. The precise dependence is given by the so-called law of atmospheres

$$n_2 = n_1 \exp [-mg (h_2 - h_1) / k_B T]$$

where n_2, n_1 refer to number density at heights h_2 and h_1 respectively. Use this relation to derive the equation for sedimentation equilibrium of a suspension in a liquid column:

$$n_2 = n_1 \exp [-mg N_A (\rho - \rho') (h_2 - h_1) / (\rho RT)]$$

where ρ is the density of the suspended particle, and ρ' that of surrounding medium. [N_A is Avogadro's number, and R the universal gas constant.] [Hint : Use Archimedes principle to find the apparent weight of the suspended particle.]

13.14 Given below are densities of some solids and liquids. Give rough estimates of the size of their atoms :

Substance	Atomic Mass (u)	Density (10^3 Kg m^{-3})
Carbon (diamond)	12.01	2.22
Gold	197.00	19.32
Nitrogen (liquid)	14.01	1.00
Lithium	6.94	0.53
Fluorine (liquid)	19.00	1.14

[Hint : Assume the atoms to be 'tightly packed' in a solid or liquid phase, and use the known value of Avogadro's number. You should, however, not take the actual numbers you obtain for various atomic sizes too literally. Because of the crudeness of the tight packing approximation, the results only indicate that atomic sizes are in the range of a few Å].