



11076CH11

CONIC SECTIONS

❖ *Let the relation of knowledge to real life be very visible to your pupils and let them understand how by knowledge the world could be transformed. – BERTRAND RUSSELL* ❖

11.1 Introduction

In the preceding Chapter 10, we have studied various forms of the equations of a line. In this Chapter, we shall study about some other curves, viz., circles, ellipses, parabolas and hyperbolas. The names parabola and hyperbola are given by Apollonius. These curves are in fact, known as *conic sections* or more commonly *conics* because they can be obtained as intersections of a plane with a double napped right circular cone. These curves have a very wide range of applications in fields such as planetary motion, design of telescopes and antennas, reflectors in flashlights and automobile headlights, etc. Now, in the subsequent sections we will see how the intersection of a plane with a double napped right circular cone results in different types of curves.



Apollonius
(262 B.C. -190 B.C.)

11.2 Sections of a Cone

Let l be a fixed vertical line and m be another line intersecting it at a fixed point V and inclined to it at an angle α (Fig 11.1).

Suppose we rotate the line m around the line l in such a way that the angle α remains constant. Then the surface generated is a double-napped right circular hollow cone herein after referred as

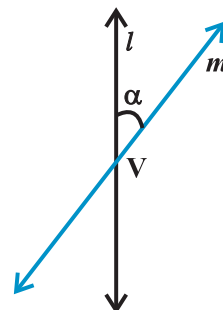

Fig 11. 1

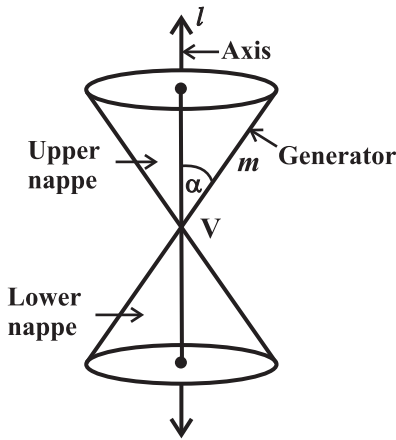

Fig 11. 2

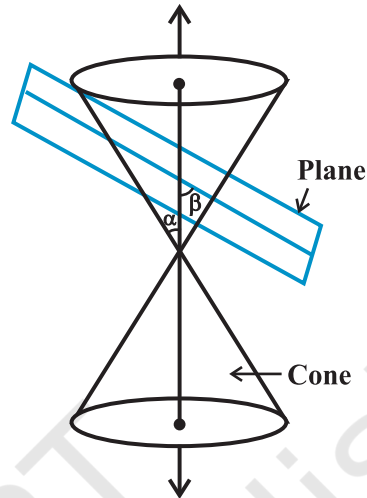

Fig 11. 3

cone and extending indefinitely far in both directions (Fig11.2).

The point V is called the *vertex*; the line l is the *axis* of the cone. The rotating line m is called a *generator* of the cone. The *vertex* separates the cone into two parts called *nappes*.

If we take the intersection of a plane with a cone, the section so obtained is called a *conic section*. Thus, conic sections are the curves obtained by intersecting a right circular cone by a plane.

We obtain different kinds of conic sections depending on the position of the intersecting plane with respect to the cone and by the angle made by it with the vertical axis of the cone. Let β be the angle made by the intersecting plane with the vertical axis of the cone (Fig11.3).

The intersection of the plane with the cone can take place either at the vertex of the cone or at any other part of the nappe either below or above the vertex.

11.2.1 Circle, ellipse, parabola and hyperbola When the plane cuts the nappe (other than the vertex) of the cone, we have the following situations:

- (a) When $\beta = 90^\circ$, the section is a *circle* (Fig11.4).
 - (b) When $\alpha < \beta < 90^\circ$, the section is an *ellipse* (Fig11.5).
 - (c) When $\beta = \alpha$; the section is a *parabola* (Fig11.6).
- (In each of the above three situations, the plane cuts entirely across one nappe of the cone).
- (d) When $0 \leq \beta < \alpha$; the plane cuts through both the nappes and the curves of intersection is a *hyperbola* (Fig11.7).

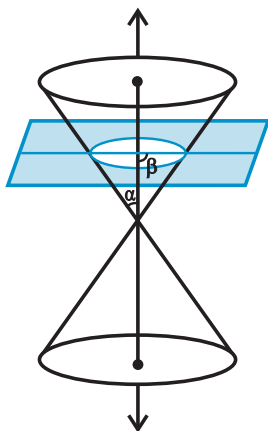

Fig 11. 4

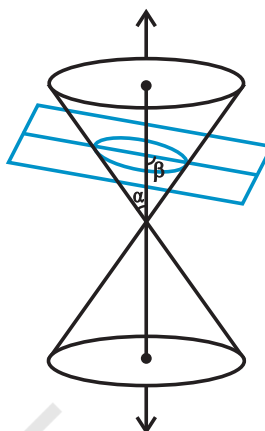

Fig 11. 5

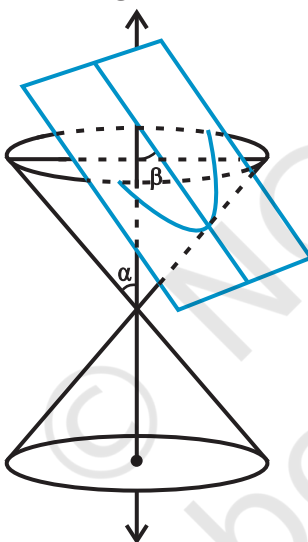

Fig 11. 6

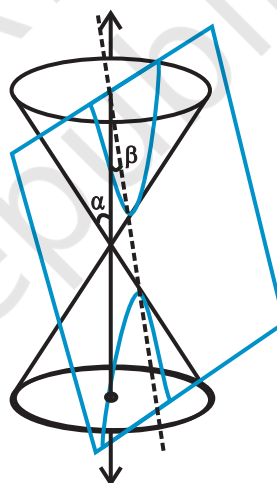

Fig 11. 7

11.2.2 Degenerated conic sections

When the plane cuts at the vertex of the cone, we have the following different cases:

- (a) When $\alpha < \beta \leq 90^\circ$, then the section is a point (Fig11.8).
- (b) When $\beta = \alpha$, the plane contains a generator of the cone and the section is a straight line (Fig11.9).

It is the degenerated case of a parabola.

- (c) When $0 \leq \beta < \alpha$, the section is a pair of intersecting straight lines (Fig11.10). It is the degenerated case of a *hyperbola*.

In the following sections, we shall obtain the equations of each of these conic sections in standard form by defining them based on geometric properties.

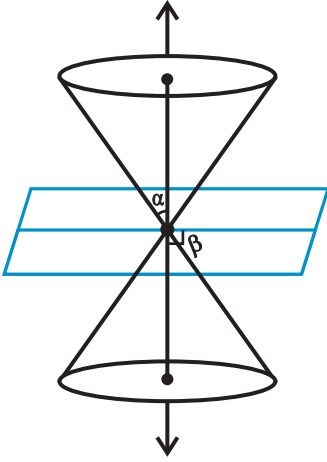

Fig 11. 8

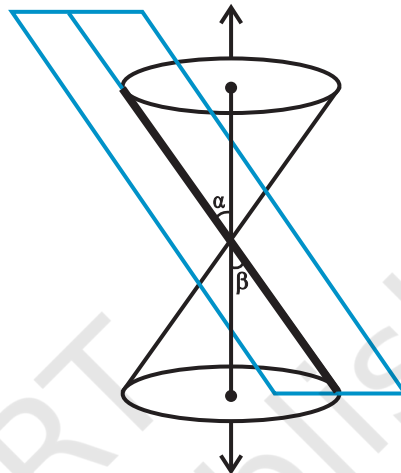
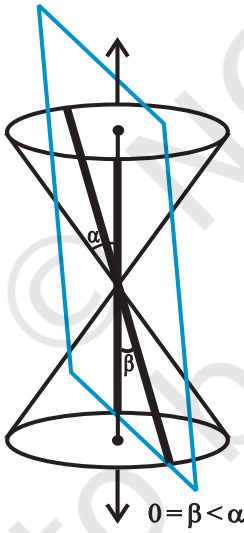
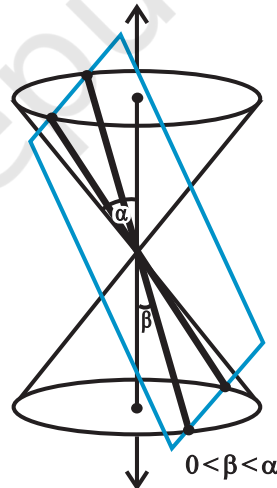

Fig 11. 9



(a)



(b)

Fig 11. 10

11.3 Circle

Definition 1 A circle is the set of all points in a plane that are equidistant from a fixed point in the plane.

The fixed point is called the *centre of the circle* and the distance from the centre to a point on the circle is called the *radius* of the circle (Fig 11.11).

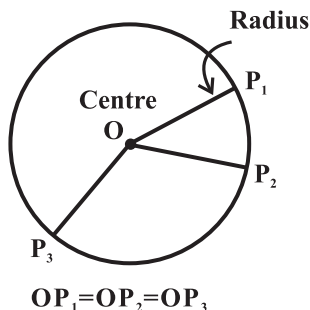

Fig 11. 11

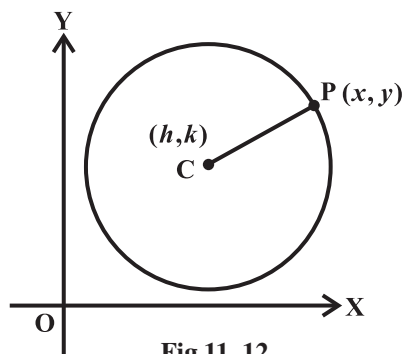

Fig 11. 12

The equation of the circle is simplest if the centre of the circle is at the origin. However, we derive below the equation of the circle with a given centre and radius (Fig 11.12).

Given $C(h, k)$ be the centre and r the radius of circle. Let $P(x, y)$ be any point on the circle (Fig 11.12). Then, by the definition, $|CP| = r$. By the distance formula, we have

$$\sqrt{(x-h)^2 + (y-k)^2} = r$$

i.e.

$$(x-h)^2 + (y-k)^2 = r^2$$

This is the required equation of the circle with centre at (h, k) and radius r .

Example 1 Find an equation of the circle with centre at $(0, 0)$ and radius r .

Solution Here $h = k = 0$. Therefore, the equation of the circle is $x^2 + y^2 = r^2$.

Example 2 Find the equation of the circle with centre $(-3, 2)$ and radius 4.

Solution Here $h = -3$, $k = 2$ and $r = 4$. Therefore, the equation of the required circle is

$$(x+3)^2 + (y-2)^2 = 16$$

Example 3 Find the centre and the radius of the circle $x^2 + y^2 + 8x + 10y - 8 = 0$

Solution The given equation is

$$(x^2 + 8x) + (y^2 + 10y) = 8$$

Now, completing the squares within the parenthesis, we get

$$(x^2 + 8x + 16) + (y^2 + 10y + 25) = 8 + 16 + 25$$

i.e.

$$(x+4)^2 + (y+5)^2 = 49$$

i.e.

$$\{x - (-4)\}^2 + \{y - (-5)\}^2 = 7^2$$

Therefore, the given circle has centre at $(-4, -5)$ and radius 7.

Example 4 Find the equation of the circle which passes through the points $(2, -2)$, and $(3,4)$ and whose centre lies on the line $x + y = 2$.

Solution Let the equation of the circle be $(x - h)^2 + (y - k)^2 = r^2$.

Since the circle passes through $(2, -2)$ and $(3,4)$, we have

$$(2 - h)^2 + (-2 - k)^2 = r^2 \quad \dots (1)$$

and $(3 - h)^2 + (4 - k)^2 = r^2 \quad \dots (2)$

Also since the centre lies on the line $x + y = 2$, we have

$$h + k = 2 \quad \dots (3)$$

Solving the equations (1), (2) and (3), we get

$$h = 0.7, \quad k = 1.3 \quad \text{and} \quad r^2 = 12.58$$

Hence, the equation of the required circle is

$$(x - 0.7)^2 + (y - 1.3)^2 = 12.58.$$

EXERCISE 11.1

In each of the following Exercises 1 to 5, find the equation of the circle with

- | | |
|--|---|
| <p>1. centre $(0,2)$ and radius 2</p> | <p>2. centre $(-2,3)$ and radius 4</p> |
| <p>3. centre $(\frac{1}{2}, \frac{1}{4})$ and radius $\frac{1}{12}$</p> | <p>4. centre $(1,1)$ and radius $\sqrt{2}$</p> |
| <p>5. centre $(-a, -b)$ and radius $\sqrt{a^2 - b^2}$.</p> | |

In each of the following Exercises 6 to 9, find the centre and radius of the circles.

- | | |
|---|--|
| <p>6. $(x + 5)^2 + (y - 3)^2 = 36$</p> | <p>7. $x^2 + y^2 - 4x - 8y - 45 = 0$</p> |
| <p>8. $x^2 + y^2 - 8x + 10y - 12 = 0$</p> | <p>9. $2x^2 + 2y^2 - x = 0$</p> |
- 10.** Find the equation of the circle passing through the points $(4,1)$ and $(6,5)$ and whose centre is on the line $4x + y = 16$.
 - 11.** Find the equation of the circle passing through the points $(2,3)$ and $(-1,1)$ and whose centre is on the line $x - 3y - 11 = 0$.
 - 12.** Find the equation of the circle with radius 5 whose centre lies on x -axis and passes through the point $(2,3)$.
 - 13.** Find the equation of the circle passing through $(0,0)$ and making intercepts a and b on the coordinate axes.
 - 14.** Find the equation of a circle with centre $(2,2)$ and passes through the point $(4,5)$.
 - 15.** Does the point $(-2.5, 3.5)$ lie inside, outside or on the circle $x^2 + y^2 = 25$?

11.4 Parabola

Definition 2 A parabola is the set of all points in a plane that are equidistant from a fixed line and a fixed point (not on the line) in the plane.

The fixed line is called the *directrix* of the parabola and the fixed point F is called the *focus* (Fig 11.13). ('Para' means 'for' and 'bola' means 'throwing', i.e., the shape described when you throw a ball in the air).

Note If the fixed point lies on the fixed line, then the set of points in the plane, which are equidistant from the fixed point and the fixed line is the straight line through the fixed point and perpendicular to the fixed line. We call this straight line as *degenerate case* of the parabola.

A line through the focus and perpendicular to the *directrix* is called the *axis* of the parabola. The point of intersection of parabola with the axis is called the *vertex* of the parabola (Fig11.14).

11.4.1 Standard equations of parabola

The equation of a *parabola* is simplest if the vertex is at the origin and the axis of symmetry is along the x -axis or y -axis. The four possible such orientations of parabola are shown below in Fig11.15 (a) to (d).

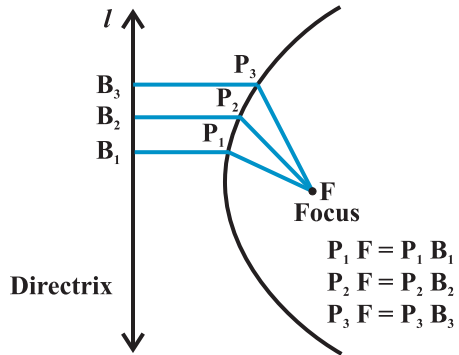

Fig 11.13

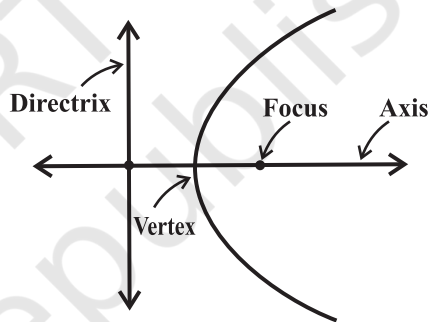
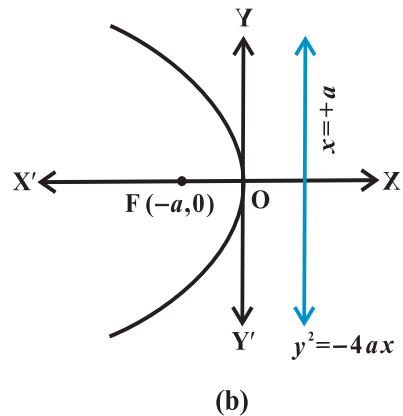
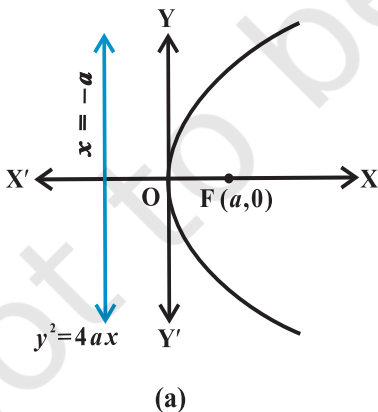

Fig 11.14



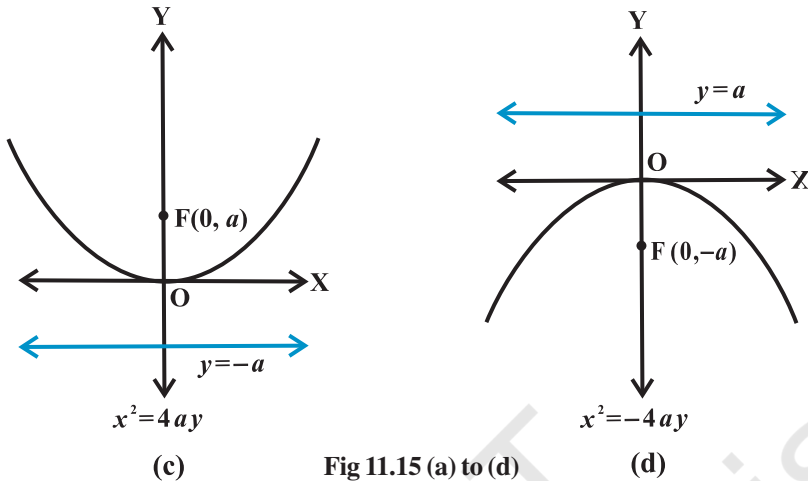

Fig 11.15 (a) to (d)

We will derive the equation for the parabola shown above in Fig 11.15 (a) with focus at $(a, 0)$ $a > 0$; and directrix $x = -a$ as below:

Let F be the focus and l the directrix. Let FM be perpendicular to the directrix and bisect FM at the point O . Produce MO to X . By the definition of parabola, the mid-point O is on the parabola and is called the vertex of the parabola. Take O as origin, OX the x -axis and OY perpendicular to it as the y -axis. Let the distance from the directrix to the focus be $2a$. Then, the coordinates of the focus are $(a, 0)$, and the equation of the directrix is $x + a = 0$ as in Fig 11.16. Let $P(x, y)$ be any point on the parabola such that

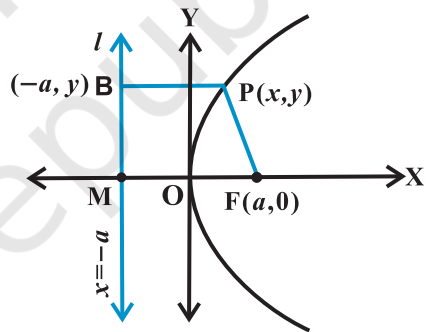

Fig 11.16

$$PF = PB,$$

$$\dots (1)$$

where PB is perpendicular to l . The coordinates of B are $(-a, y)$. By the distance formula, we have

$$PF = \sqrt{(x - a)^2 + y^2} \text{ and } PB = \sqrt{(x + a)^2}$$

Since $PF = PB$, we have

$$\sqrt{(x - a)^2 + y^2} = \sqrt{(x + a)^2}$$

i.e. $(x - a)^2 + y^2 = (x + a)^2$

or $x^2 - 2ax + a^2 + y^2 = x^2 + 2ax + a^2$

or $y^2 = 4ax$ ($a > 0$).

Hence, any point on the parabola satisfies

$$y^2 = 4ax. \quad \dots (2)$$

Conversely, let $P(x, y)$ satisfy the equation (2)

$$\begin{aligned} \text{PF} &= \sqrt{(x-a)^2 + y^2} = \sqrt{(x-a)^2 + 4ax} \\ &= \sqrt{(x+a)^2} = \text{PB} \end{aligned} \quad \dots (3)$$

and so $P(x, y)$ lies on the parabola.

Thus, from (2) and (3) we have proved that the equation to the parabola with vertex at the origin, focus at $(a, 0)$ and directrix $x = -a$ is $y^2 = 4ax$.

Discussion In equation (2), since $a > 0$, x can assume any positive value or zero but no negative value and the curve extends indefinitely far into the first and the fourth quadrants. The axis of the parabola is the positive x -axis.

Similarly, we can derive the equations of the parabolas in:

Fig 11.15 (b) as $y^2 = -4ax$,

Fig 11.15 (c) as $x^2 = 4ay$,

Fig 11.15 (d) as $x^2 = -4ay$,

These four equations are known as *standard equations* of parabolas.

 **Note** The standard equations of parabolas have focus on one of the coordinate axis; vertex at the *origin* and thereby the directrix is parallel to the other coordinate axis. However, the study of the equations of parabolas with focus at any point and any line as directrix is beyond the scope here.

From the standard equations of the parabolas, Fig 11.15, we have the following observations:

1. Parabola is symmetric with respect to the axis of the parabola. If the equation has a y^2 term, then the axis of symmetry is along the x -axis and if the equation has an x^2 term, then the axis of symmetry is along the y -axis.
2. When the axis of symmetry is along the x -axis the parabola opens to the
 - (a) right if the coefficient of x is positive,
 - (b) left if the coefficient of x is negative.
3. When the axis of symmetry is along the y -axis the parabola opens
 - (c) upwards if the coefficient of y is positive.
 - (d) downwards if the coefficient of y is negative.

11.4.2 Latus rectum

Definition 3 Latus rectum of a parabola is a line segment perpendicular to the axis of the parabola, through the focus and whose end points lie on the parabola (Fig 11.17).

To find the Length of the latus rectum of the parabola $y^2 = 4ax$ (Fig 11.18).

By the definition of the parabola, $AF = AC$.

But $AC = FM = 2a$

Hence $AF = 2a$.

And since the parabola is symmetric with respect to x -axis $AF = FB$ and so

$AB = \text{Length of the latus rectum} = 4a$.

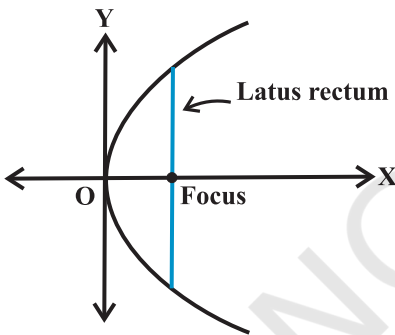

Fig 11.17

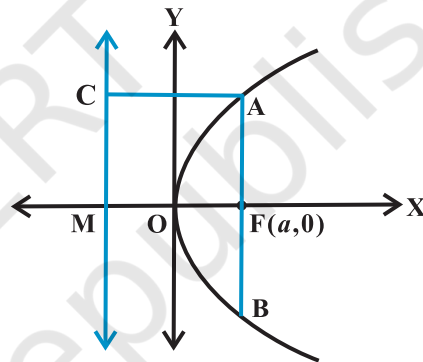

Fig 11.18

Example 5 Find the coordinates of the focus, axis, the equation of the directrix and latus rectum of the parabola $y^2 = 8x$.

Solution The given equation involves y^2 , so the axis of symmetry is along the x -axis. The coefficient of x is positive so the parabola opens to the right. Comparing with the given equation $y^2 = 4ax$, we find that $a = 2$.

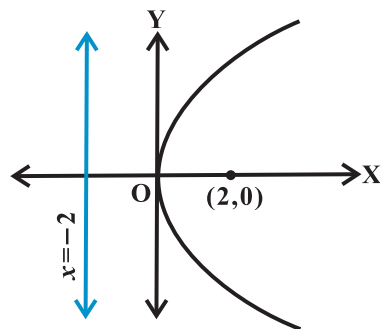

Fig 11.19

Thus, the focus of the parabola is $(2, 0)$ and the equation of the directrix of the parabola is $x = -2$ (Fig 11.19).

Length of the latus rectum is $4a = 4 \times 2 = 8$.

Example 6 Find the equation of the parabola with focus $(2,0)$ and directrix $x = -2$.

Solution Since the focus $(2,0)$ lies on the x -axis, the x -axis itself is the axis of the parabola. Hence the equation of the parabola is of the form either $y^2 = 4ax$ or $y^2 = -4ax$. Since the directrix is $x = -2$ and the focus is $(2,0)$, the parabola is to be of the form $y^2 = 4ax$ with $a = 2$. Hence the required equation is

$$y^2 = 4(2)x = 8x$$

Example 7 Find the equation of the parabola with vertex at $(0, 0)$ and focus at $(0, 2)$.

Solution Since the vertex is at $(0,0)$ and the focus is at $(0,2)$ which lies on y -axis, the y -axis is the axis of the parabola. Therefore, equation of the parabola is of the form $x^2 = 4ay$. thus, we have

$$x^2 = 4(2)y, \text{ i.e., } x^2 = 8y.$$

Example 8 Find the equation of the parabola which is symmetric about the y -axis, and passes through the point $(2,-3)$.

Solution Since the parabola is symmetric about y -axis and has its vertex at the origin, the equation is of the form $x^2 = 4ay$ or $x^2 = -4ay$, where the sign depends on whether the parabola opens upwards or downwards. But the parabola passes through $(2,-3)$ which lies in the fourth quadrant, it must open downwards. Thus the equation is of the form $x^2 = -4ay$.

Since the parabola passes through $(2,-3)$, we have

$$2^2 = -4a(-3), \text{ i.e., } a = \frac{1}{3}$$

Therefore, the equation of the parabola is

$$x^2 = -4\left(\frac{1}{3}\right)y, \text{ i.e., } 3x^2 = -4y.$$

EXERCISE 11.2

In each of the following Exercises 1 to 6, find the coordinates of the focus, axis of the parabola, the equation of the directrix and the length of the latus rectum.

- | | | |
|-----------------|----------------|----------------|
| 1. $y^2 = 12x$ | 2. $x^2 = 6y$ | 3. $y^2 = -8x$ |
| 4. $x^2 = -16y$ | 5. $y^2 = 10x$ | 6. $x^2 = -9y$ |

In each of the Exercises 7 to 12, find the equation of the parabola that satisfies the given conditions:

- 7. Focus (6,0); directrix $x = -6$
- 8. Focus (0,-3); directrix $y = 3$
- 9. Vertex (0,0); focus (3,0)
- 10. Vertex (0,0); focus (-2,0)
- 11. Vertex (0,0) passing through (2,3) and axis is along x -axis.
- 12. Vertex (0,0), passing through (5,2) and symmetric with respect to y -axis.

11.5 Ellipse

Definition 4 An *ellipse* is the set of all points in a plane, the sum of whose distances from two fixed points in the plane is a constant.

The two fixed points are called the *foci* (plural of 'focus') of the ellipse (Fig11.20).

Note The constant which is the sum of the distances of a point on the ellipse from the two fixed points is always greater than the distance between the two fixed points.

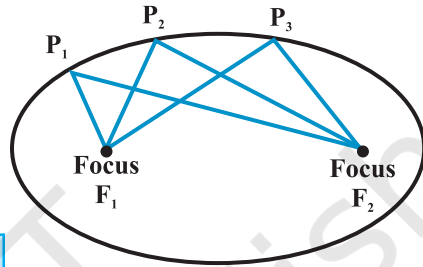

$$P_1F_1 + P_1F_2 = P_2F_1 + P_2F_2 = P_3F_1 + P_3F_2$$

Fig 11.20

The mid point of the line segment joining the foci is called the *centre* of the ellipse. The line segment through the foci of the ellipse is called the *major axis* and the line segment through the centre and perpendicular to the major axis is called the *minor axis*. The end points of the major axis are called the *vertices* of the ellipse(Fig 11.21).

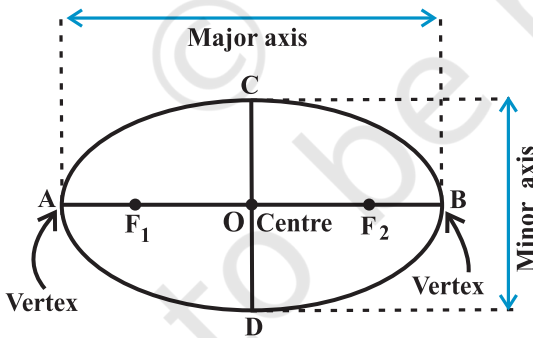

Fig 11.21

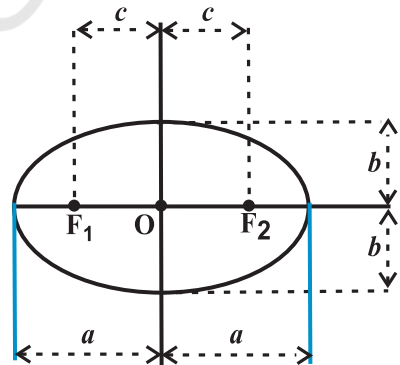

Fig 11.22

We denote the length of the major axis by $2a$, the length of the minor axis by $2b$ and the distance between the foci by $2c$. Thus, the length of the semi major axis is a and semi-minor axis is b (Fig11.22).

11.5.1 Relationship between semi-major axis, semi-minor axis and the distance of the focus from the centre of the ellipse (Fig 11.23).

Take a point P at one end of the major axis. R

Sum of the distances of the point P to the foci is $F_1P + F_2P = F_1O + OP + F_2P$

$$\begin{aligned} \text{(Since, } F_1P &= F_1O + OP) \\ &= c + a + a - c = 2a \end{aligned}$$

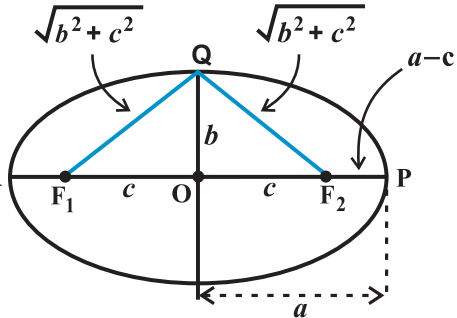

Fig 11.23

Take a point Q at one end of the minor axis.

Sum of the distances from the point Q to the foci is

$$F_1Q + F_2Q = \sqrt{b^2 + c^2} + \sqrt{b^2 + c^2} = 2\sqrt{b^2 + c^2}$$

Since both P and Q lies on the ellipse.

By the definition of ellipse, we have

$$2\sqrt{b^2 + c^2} = 2a, \text{ i.e., } a = \sqrt{b^2 + c^2}$$

or $a^2 = b^2 + c^2, \text{ i.e., } c = \sqrt{a^2 - b^2}$

11.5.2 Special cases of an ellipse In the equation $c^2 = a^2 - b^2$ obtained above, if we keep a fixed and vary c from 0 to a , the resulting ellipses will vary in shape.

Case (i) When $c = 0$, both foci merge together with the centre of the ellipse and $a^2 = b^2$, i.e., $a = b$, and so the ellipse becomes circle (Fig11.24). Thus, circle is a special case of an ellipse which is dealt in Section 11.3.

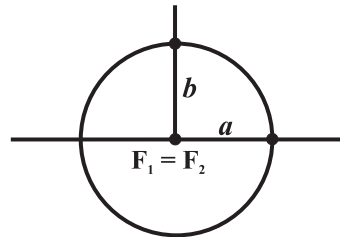

Fig 11.24

Case (ii) When $c = a$, then $b = 0$. The ellipse reduces to the line segment F_1F_2 joining the two foci (Fig11.25).



Fig 11.25

11.5.3 Eccentricity

Definition 5 The eccentricity of an ellipse is the ratio of the distances from the centre of the ellipse to one of the foci and to one of the vertices of the ellipse (eccentricity is

denoted by e) i.e., $e = \frac{c}{a}$.

Then since the focus is at a distance of c from the centre, in terms of the eccentricity the focus is at a distance of ae from the centre.

11.5.4 Standard equations of an ellipse The equation of an ellipse is simplest if the centre of the ellipse is at the origin and the foci are

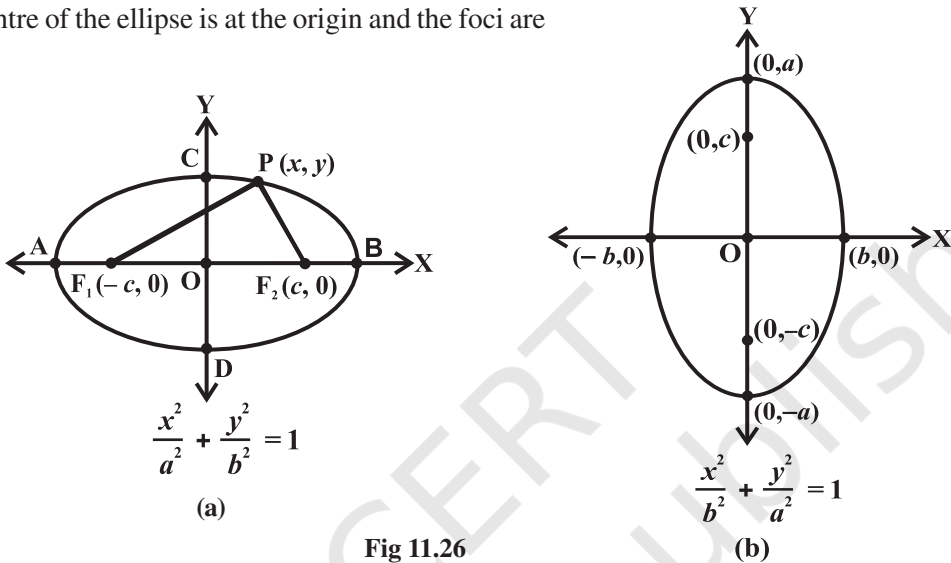

Fig 11.26

on the x -axis or y -axis. The two such possible orientations are shown in Fig 11.26.

We will derive the equation for the ellipse shown above in Fig 11.26 (a) with foci on the x -axis.

Let F_1 and F_2 be the foci and O be the mid-point of the line segment F_1F_2 . Let O be the origin and the line from O through F_2 be the positive x -axis and that through F_1 as the negative x -axis. Let, the line through O perpendicular to the x -axis be the y -axis. Let the coordinates of F_1 be $(-c, 0)$ and F_2 be $(c, 0)$ (Fig 11.27).

Let $P(x, y)$ be any point on the ellipse such that the sum of the distances from P to the two foci be $2a$ so given

$$PF_1 + PF_2 = 2a. \quad \dots (1)$$

Using the distance formula, we have

$$\sqrt{(x+c)^2 + y^2} + \sqrt{(x-c)^2 + y^2} = 2a$$

i.e., $\sqrt{(x+c)^2 + y^2} = 2a - \sqrt{(x-c)^2 + y^2}$

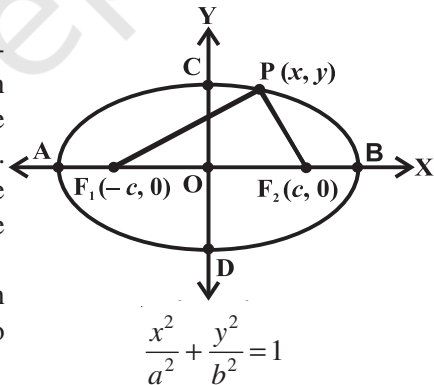

Fig 11.27

Squaring both sides, we get

$$(x + c)^2 + y^2 = 4a^2 - 4a \sqrt{(x - c)^2 + y^2} + (x - c)^2 + y^2$$

which on simplification gives

$$\sqrt{(x - c)^2 + y^2} = a - \frac{c}{a} x$$

Squaring again and simplifying, we get

$$\frac{x^2}{a^2} + \frac{y^2}{a^2 - c^2} = 1$$

i.e., $\frac{x^2}{a^2} + \frac{y^2}{b^2} = 1$ (Since $c^2 = a^2 - b^2$)

Hence any point on the ellipse satisfies

$$\frac{x^2}{a^2} + \frac{y^2}{b^2} = 1. \quad \dots (2)$$

Conversely, let P (x, y) satisfy the equation (2) with $0 < c < a$. Then

$$y^2 = b^2 \left(1 - \frac{x^2}{a^2} \right)$$

$$\begin{aligned} \text{Therefore, } PF_1 &= \sqrt{(x+c)^2 + y^2} \\ &= \sqrt{(x+c)^2 + b^2 \left(\frac{a^2 - x^2}{a^2} \right)} \\ &= \sqrt{(x+c)^2 + (a^2 - c^2) \left(\frac{a^2 - x^2}{a^2} \right)} \quad (\text{since } b^2 = a^2 - c^2) \\ &= \sqrt{\left(a + \frac{cx}{a} \right)^2} = a + \frac{c}{a} x \end{aligned}$$

Similarly $PF_2 = a - \frac{c}{a} x$

Hence
$$PF_1 + PF_2 = a + \frac{c}{a}x + a - \frac{c}{a}x = 2a \quad \dots (3)$$

So, any point that satisfies $\frac{x^2}{a^2} + \frac{y^2}{b^2} = 1$, satisfies the geometric condition and so

$P(x, y)$ lies on the ellipse.

Hence from (2) and (3), we proved that the equation of an ellipse with centre of the origin and major axis along the x -axis is

$$\frac{x^2}{a^2} + \frac{y^2}{b^2} = 1.$$

Discussion From the equation of the ellipse obtained above, it follows that for every point $P(x, y)$ on the ellipse, we have

$$\frac{x^2}{a^2} = 1 - \frac{y^2}{b^2} \leq 1, \text{ i.e., } x^2 \leq a^2, \text{ so } -a \leq x \leq a.$$

Therefore, the ellipse lies between the lines $x = -a$ and $x = a$ and touches these lines.

Similarly, the ellipse lies between the lines $y = -b$ and $y = b$ and touches these lines.

Similarly, we can derive the equation of the ellipse in Fig 11.26 (b) as $\frac{x^2}{b^2} + \frac{y^2}{a^2} = 1$.

These two equations are known as *standard equations* of the ellipses.

 **Note** The standard equations of ellipses have centre at the origin and the major and minor axis are coordinate axes. However, the study of the ellipses with centre at any other point, and any line through the centre as major and the minor axes passing through the centre and perpendicular to major axis are beyond the scope here.

From the standard equations of the ellipses (Fig11.26), we have the following observations:

1. Ellipse is symmetric with respect to both the coordinate axes since if (x, y) is a point on the ellipse, then $(-x, y)$, $(x, -y)$ and $(-x, -y)$ are also points on the ellipse.

2. The foci always lie on the major axis. The major axis can be determined by finding the intercepts on the axes of symmetry. That is, major axis is along the x -axis if the coefficient of x^2 has the larger denominator and it is along the y -axis if the coefficient of y^2 has the larger denominator.

11.5.5 Latus rectum

Definition 6 Latus rectum of an ellipse is a line segment perpendicular to the major axis through any of the foci and whose end points lie on the ellipse (Fig 11.28).

To find the length of the latus rectum

of the ellipse $\frac{x^2}{a^2} + \frac{y^2}{b^2} = 1$

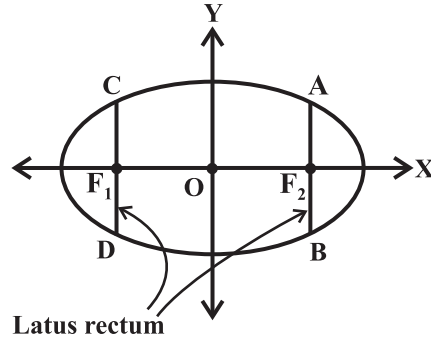

Fig 11.28

Let the length of AF_2 be l .

Then the coordinates of A are (c, l) , i.e., (ae, l)

Since A lies on the ellipse $\frac{x^2}{a^2} + \frac{y^2}{b^2} = 1$, we have

$$\frac{(ae)^2}{a^2} + \frac{l^2}{b^2} = 1$$

$$\Rightarrow l^2 = b^2 (1 - e^2)$$

But $e^2 = \frac{c^2}{a^2} = \frac{a^2 - b^2}{a^2} = 1 - \frac{b^2}{a^2}$

Therefore $l^2 = \frac{b^4}{a^2}$, i.e., $l = \frac{b^2}{a}$

Since the ellipse is symmetric with respect to y-axis (of course, it is symmetric w.r.t.

both the coordinate axes), $AF_2 = F_2B$ and so length of the latus rectum is $\frac{2b^2}{a}$.

Example 9 Find the coordinates of the foci, the vertices, the length of major axis, the minor axis, the eccentricity and the latus rectum of the ellipse

$$\frac{x^2}{25} + \frac{y^2}{9} = 1$$

Solution Since denominator of $\frac{x^2}{25}$ is larger than the denominator of $\frac{y^2}{9}$, the major

axis is along the x -axis. Comparing the given equation with $\frac{x^2}{a^2} + \frac{y^2}{b^2} = 1$, we get

$$a = 5 \text{ and } b = 3. \text{ Also}$$

$$c = \sqrt{a^2 - b^2} = \sqrt{25 - 9} = 4$$

Therefore, the coordinates of the foci are $(-4, 0)$ and $(4, 0)$, vertices are $(-5, 0)$ and $(5, 0)$. Length of the major axis is 10 units length of the minor axis $2b$ is 6 units and the

eccentricity is $\frac{4}{5}$ and latus rectum is $\frac{2b^2}{a} = \frac{18}{5}$.

Example 10 Find the coordinates of the foci, the vertices, the lengths of major and minor axes and the eccentricity of the ellipse $9x^2 + 4y^2 = 36$.

Solution The given equation of the ellipse can be written in standard form as

$$\frac{x^2}{4} + \frac{y^2}{9} = 1$$

Since the denominator of $\frac{y^2}{9}$ is larger than the denominator of $\frac{x^2}{4}$, the major axis is along the y -axis. Comparing the given equation with the standard equation

$$\frac{x^2}{b^2} + \frac{y^2}{a^2} = 1, \text{ we have } b = 2 \text{ and } a = 3.$$

Also
$$c = \sqrt{a^2 - b^2} = \sqrt{9 - 4} = \sqrt{5}$$

and
$$e = \frac{c}{a} = \frac{\sqrt{5}}{3}$$

Hence the foci are $(0, \sqrt{5})$ and $(0, -\sqrt{5})$, vertices are $(0, 3)$ and $(0, -3)$, length of the major axis is 6 units, the length of the minor axis is 4 units and the eccentricity of the

ellipse is $\frac{\sqrt{5}}{3}$.

Example 11 Find the equation of the ellipse whose vertices are $(\pm 13, 0)$ and foci are $(\pm 5, 0)$.

Solution Since the vertices are on x -axis, the equation will be of the form

$$\frac{x^2}{a^2} + \frac{y^2}{b^2} = 1, \text{ where } a \text{ is the semi-major axis.}$$

Given that $a = 13, c = \pm 5$.

Therefore, from the relation $c^2 = a^2 - b^2$, we get

$$25 = 169 - b^2, \text{ i.e., } b = 12$$

Hence the equation of the ellipse is $\frac{x^2}{169} + \frac{y^2}{144} = 1$.

Example 12 Find the equation of the ellipse, whose length of the major axis is 20 and foci are $(0, \pm 5)$.

Solution Since the foci are on y -axis, the major axis is along the y -axis. So, equation

of the ellipse is of the form $\frac{x^2}{b^2} + \frac{y^2}{a^2} = 1$.

Given that

$$a = \text{semi-major axis} = \frac{20}{2} = 10$$

and the relation

$$c^2 = a^2 - b^2 \text{ gives}$$

$$5^2 = 10^2 - b^2 \text{ i.e., } b^2 = 75$$

Therefore, the equation of the ellipse is

$$\frac{x^2}{75} + \frac{y^2}{100} = 1$$

Example 13 Find the equation of the ellipse, with major axis along the x -axis and passing through the points $(4, 3)$ and $(-1, 4)$.

Solution The standard form of the ellipse is $\frac{x^2}{a^2} + \frac{y^2}{b^2} = 1$. Since the points $(4, 3)$ and $(-1, 4)$ lie on the ellipse, we have

$$\frac{16}{a^2} + \frac{9}{b^2} = 1 \quad \dots (1)$$

and $\frac{1}{a^2} + \frac{16}{b^2} = 1 \quad \dots (2)$

Solving equations (1) and (2), we find that $a^2 = \frac{247}{7}$ and $b^2 = \frac{247}{15}$.

Hence the required equation is

$$\left(\frac{x^2}{\frac{247}{7}}\right) + \frac{y^2}{15} = 1, \text{ i.e., } 7x^2 + 15y^2 = 247.$$

EXERCISE 11.3

In each of the Exercises 1 to 9, find the coordinates of the foci, the vertices, the length of major axis, the minor axis, the eccentricity and the length of the latus rectum of the ellipse.

1. $\frac{x^2}{36} + \frac{y^2}{16} = 1$
2. $\frac{x^2}{4} + \frac{y^2}{25} = 1$
3. $\frac{x^2}{16} + \frac{y^2}{9} = 1$
4. $\frac{x^2}{25} + \frac{y^2}{100} = 1$
5. $\frac{x^2}{49} + \frac{y^2}{36} = 1$
6. $\frac{x^2}{100} + \frac{y^2}{400} = 1$
7. $36x^2 + 4y^2 = 144$
8. $16x^2 + y^2 = 16$
9. $4x^2 + 9y^2 = 36$

In each of the following Exercises 10 to 20, find the equation for the ellipse that satisfies the given conditions:

10. Vertices $(\pm 5, 0)$, foci $(\pm 4, 0)$
11. Vertices $(0, \pm 13)$, foci $(0, \pm 5)$
12. Vertices $(\pm 6, 0)$, foci $(\pm 4, 0)$
13. Ends of major axis $(\pm 3, 0)$, ends of minor axis $(0, \pm 2)$
14. Ends of major axis $(0, \pm \sqrt{5})$, ends of minor axis $(\pm 1, 0)$
15. Length of major axis 26, foci $(\pm 5, 0)$
16. Length of minor axis 16, foci $(0, \pm 6)$.
17. Foci $(\pm 3, 0)$, $a = 4$
18. $b = 3$, $c = 4$, centre at the origin; foci on the x axis.
19. Centre at $(0,0)$, major axis on the y -axis and passes through the points $(3, 2)$ and $(1,6)$.
20. Major axis on the x -axis and passes through the points $(4,3)$ and $(6,2)$.

11.6 Hyperbola

Definition 7 A hyperbola is the set of all points in a plane, the difference of whose distances from two fixed points in the plane is a constant.

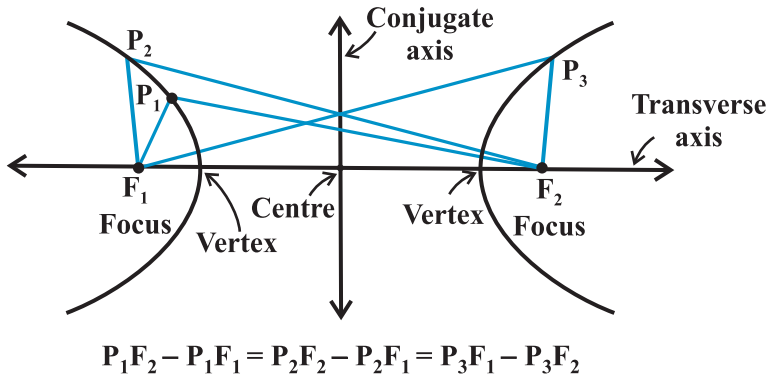

Fig 11.29

The term “*difference*” that is used in the definition means the distance to the farther point minus the distance to the closer point. The two fixed points are called the foci of the hyperbola. The mid-point of the line segment joining the foci is called the *centre of the hyperbola*. The line through the foci is called the *transverse axis* and the line through the centre and perpendicular to the transverse axis is called the *conjugate axis*. The points at which the hyperbola intersects the transverse axis are called the *vertices of the hyperbola* (Fig 11.29).

We denote the distance between the two foci by $2c$, the distance between two vertices (the length of the transverse axis) by $2a$ and we define the quantity b as

$$b = \sqrt{c^2 - a^2}$$

Also $2b$ is the length of the conjugate axis (Fig 11.30).

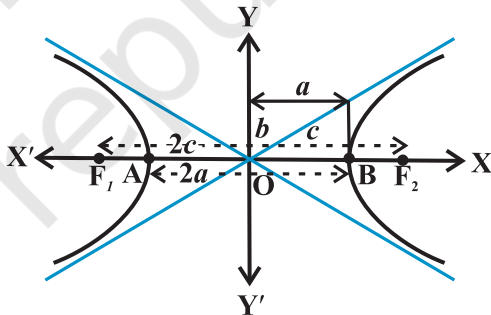

Fig 11.30

To find the constant $P_1F_2 - P_1F_1$:

By taking the point P at A and B in the Fig 11.30, we have

$$BF_1 - BF_2 = AF_2 - AF_1 \text{ (by the definition of the hyperbola)}$$

$$BA + AF_1 - BF_2 = AB + BF_2 - AF_1$$

$$\text{i.e., } AF_1 = BF_2$$

$$\text{So that, } BF_1 - BF_2 = BA + AF_1 - BF_2 = BA = 2a$$

11.6.1 Eccentricity

Definition 8 Just like an ellipse, the ratio $e = \frac{c}{a}$ is called the *eccentricity of the hyperbola*. Since $c \geq a$, the eccentricity is never less than one. In terms of the eccentricity, the foci are at a distance of ae from the centre.

11.6.2 Standard equation of Hyperbola The equation of a hyperbola is simplest if the centre of the hyperbola is at the origin and the foci are on the x -axis or y -axis. The two such possible orientations are shown in Fig 11.31.

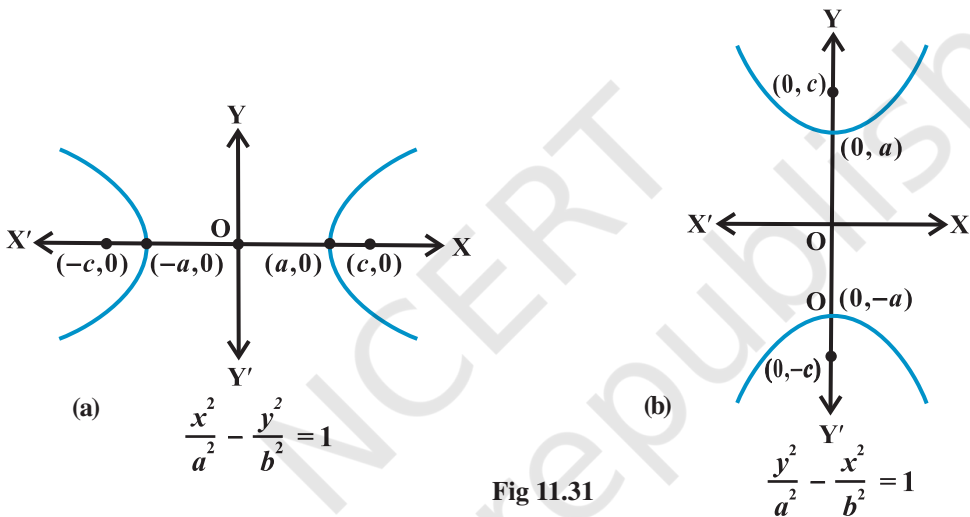

Fig 11.31

We will derive the equation for the hyperbola shown in Fig 11.31(a) with foci on the x -axis.

Let F_1 and F_2 be the foci and O be the mid-point of the line segment F_1F_2 . Let O be the origin and the line through O through F_2 be the positive x -axis and that through F_1 as the negative x -axis. The line through O perpendicular to the x -axis is the y -axis. Let the coordinates of F_1 be $(-c, 0)$ and F_2 be $(c, 0)$ (Fig 11.32).

Let $P(x, y)$ be any point on the hyperbola such that the difference of the distances from P to the farther point minus the closer point be $2a$. So given, $PF_1 - PF_2 = 2a$

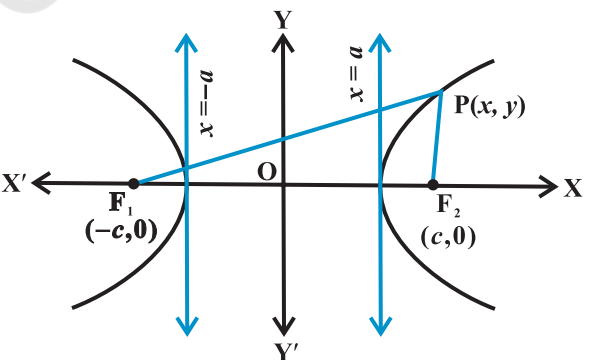

Fig 11.32

Using the distance formula, we have

$$\sqrt{(x+c)^2 + y^2} - \sqrt{(x-c)^2 + y^2} = 2a$$

i.e.,
$$\sqrt{(x+c)^2 + y^2} = 2a + \sqrt{(x-c)^2 + y^2}$$

Squaring both side, we get

$$(x+c)^2 + y^2 = 4a^2 + 4a \sqrt{(x-c)^2 + y^2} + (x-c)^2 + y^2$$

and on simplifying, we get

$$\frac{cx}{a} - a = \sqrt{(x-c)^2 + y^2}$$

On squaring again and further simplifying, we get

$$\frac{x^2}{a^2} - \frac{y^2}{c^2 - a^2} = 1$$

i.e.,
$$\frac{x^2}{a^2} - \frac{y^2}{b^2} = 1 \quad (\text{Since } c^2 - a^2 = b^2)$$

Hence any point on the hyperbola satisfies $\frac{x^2}{a^2} - \frac{y^2}{b^2} = 1$

Conversely, let P(x, y) satisfy the above equation with $0 < a < c$. Then

$$y^2 = b^2 \left(\frac{x^2 - a^2}{a^2} \right)$$

Therefore,
$$\begin{aligned} PF_1 &= + \sqrt{(x+c)^2 + y^2} \\ &= + \sqrt{(x+c)^2 + b^2 \left(\frac{x^2 - a^2}{a^2} \right)} = a + \frac{c}{a} x \end{aligned}$$

Similarly,
$$PF_2 = a - \frac{a}{c} x$$

In hyperbola $c > a$; and since P is to the right of the line $x = a$, $x > a$, $\frac{c}{a} x > a$. Therefore,

$a - \frac{c}{a} x$ becomes negative. Thus, $PF_2 = \frac{c}{a} x - a$.

Therefore $PF_1 - PF_2 = a + \frac{c}{a}x - \frac{cx}{a} + a = 2a$

Also, note that if P is to the left of the line $x = -a$, then

$$PF_1 = -\left(a + \frac{c}{a}x\right), \quad PF_2 = a - \frac{c}{a}x.$$

In that case $PF_2 - PF_1 = 2a$. So, any point that satisfies $\frac{x^2}{a^2} - \frac{y^2}{b^2} = 1$, lies on the hyperbola.

Thus, we proved that the equation of hyperbola with origin (0,0) and transverse axis

along x-axis is $\frac{x^2}{a^2} - \frac{y^2}{b^2} = 1$.

 **Note** A hyperbola in which $a = b$ is called an *equilateral hyperbola*.

Discussion From the equation of the hyperbola we have obtained, it follows that, we

have for every point (x, y) on the hyperbola, $\frac{x^2}{a^2} = 1 + \frac{y^2}{b^2} \geq 1$.

i.e., $\left|\frac{x}{a}\right| \geq 1$, i.e., $x \leq -a$ or $x \geq a$. Therefore, no portion of the curve lies between the lines $x = +a$ and $x = -a$, (i.e. no real intercept on the conjugate axis).

Similarly, we can derive the equation of the hyperbola in Fig 11.31 (b) as $\frac{y^2}{a^2} - \frac{x^2}{b^2} = 1$

These two equations are known as the *standard equations of hyperbolas*.

 **Note** The standard equations of hyperbolas have transverse and conjugate axes as the coordinate axes and the centre at the origin. However, there are hyperbolas with any two perpendicular lines as transverse and conjugate axes, but the study of such cases will be dealt in higher classes.

From the standard equations of hyperbolas (Fig11.29), we have the following observations:

1. Hyperbola is symmetric with respect to both the axes, since if (x, y) is a point on the hyperbola, then $(-x, y)$, $(x, -y)$ and $(-x, -y)$ are also points on the hyperbola.

2. The foci are always on the transverse axis. It is the positive term whose

denominator gives the transverse axis. For example, $\frac{x^2}{9} - \frac{y^2}{16} = 1$

has transverse axis along x -axis of length 6, while $\frac{y^2}{25} - \frac{x^2}{16} = 1$

has transverse axis along y -axis of length 10.

11.6.3 Latus rectum

Definition 9 Latus rectum of hyperbola is a line segment perpendicular to the transverse axis through any of the foci and whose end points lie on the hyperbola.

As in ellipse, it is easy to show that the length of the latus rectum in hyperbola is $\frac{2b^2}{a}$.

Example 14 Find the coordinates of the foci and the vertices, the eccentricity, the length of the latus rectum of the hyperbolas:

$$(i) \frac{x^2}{9} - \frac{y^2}{16} = 1, (ii) y^2 - 16x^2 = 16$$

Solution (i) Comparing the equation $\frac{x^2}{9} - \frac{y^2}{16} = 1$ with the standard equation

$$\frac{x^2}{a^2} - \frac{y^2}{b^2} = 1$$

Here, $a = 3$, $b = 4$ and $c = \sqrt{a^2 + b^2} = \sqrt{9 + 16} = 5$

Therefore, the coordinates of the foci are $(\pm 5, 0)$ and that of vertices are $(\pm 3, 0)$. Also,

The eccentricity $e = \frac{c}{a} = \frac{5}{3}$. The latus rectum $= \frac{2b^2}{a} = \frac{32}{3}$

(ii) Dividing the equation by 16 on both sides, we have $\frac{y^2}{16} - \frac{x^2}{1} = 1$

Comparing the equation with the standard equation $\frac{y^2}{a^2} - \frac{x^2}{b^2} = 1$, we find that

$a = 4$, $b = 1$ and $c = \sqrt{a^2 + b^2} = \sqrt{16 + 1} = \sqrt{17}$.

Therefore, the coordinates of the foci are $(0, \pm \sqrt{17})$ and that of the vertices are $(0, \pm 4)$. Also,

The eccentricity $e = \frac{c}{a} = \frac{\sqrt{17}}{4}$. The latus rectum $= \frac{2b^2}{a} = \frac{1}{2}$.

Example 15 Find the equation of the hyperbola with foci $(0, \pm 3)$ and vertices $(0, \pm \frac{\sqrt{11}}{2})$.

Solution Since the foci is on y-axis, the equation of the hyperbola is of the form

$$\frac{y^2}{a^2} - \frac{x^2}{b^2} = 1$$

Since vertices are $(0, \pm \frac{\sqrt{11}}{2})$, $a = \frac{\sqrt{11}}{2}$

Also, since foci are $(0, \pm 3)$; $c = 3$ and $b^2 = c^2 - a^2 = \frac{25}{4}$.

Therefore, the equation of the hyperbola is

$$\frac{y^2}{\left(\frac{11}{4}\right)} - \frac{x^2}{\left(\frac{25}{4}\right)} = 1, \text{ i.e., } 100y^2 - 44x^2 = 275.$$

Example 16 Find the equation of the hyperbola where foci are $(0, \pm 12)$ and the length of the latus rectum is 36.

Solution Since foci are $(0, \pm 12)$, it follows that $c = 12$.

Length of the latus rectum $= \frac{2b^2}{a} = 36$ or $b^2 = 18a$

Therefore $c^2 = a^2 + b^2$; gives

$$144 = a^2 + 18a$$

i.e., $a^2 + 18a - 144 = 0$,

So $a = -24, 6$.

Since a cannot be negative, we take $a = 6$ and so $b^2 = 108$.

Therefore, the equation of the required hyperbola is $\frac{y^2}{36} - \frac{x^2}{108} = 1$, i.e., $3y^2 - x^2 = 108$

EXERCISE 11.4

In each of the Exercises 1 to 6, find the coordinates of the foci and the vertices, the eccentricity and the length of the latus rectum of the hyperbolas.

1. $\frac{x^2}{16} - \frac{y^2}{9} = 1$
2. $\frac{y^2}{9} - \frac{x^2}{27} = 1$
3. $9y^2 - 4x^2 = 36$
4. $16x^2 - 9y^2 = 576$
5. $5y^2 - 9x^2 = 36$
6. $49y^2 - 16x^2 = 784$.

In each of the Exercises 7 to 15, find the equations of the hyperbola satisfying the given conditions.

7. Vertices $(\pm 2, 0)$, foci $(\pm 3, 0)$
8. Vertices $(0, \pm 5)$, foci $(0, \pm 8)$
9. Vertices $(0, \pm 3)$, foci $(0, \pm 5)$
10. Foci $(\pm 5, 0)$, the transverse axis is of length 8.
11. Foci $(0, \pm 13)$, the conjugate axis is of length 24.
12. Foci $(\pm 3\sqrt{5}, 0)$, the latus rectum is of length 8.
13. Foci $(\pm 4, 0)$, the latus rectum is of length 12
14. vertices $(\pm 7, 0)$, $e = \frac{4}{3}$.
15. Foci $(0, \pm \sqrt{10})$, passing through $(2, 3)$

Miscellaneous Examples

Example 17 The focus of a parabolic mirror as shown in Fig 11.33 is at a distance of 5 cm from its vertex. If the mirror is 45 cm deep, find the distance AB (Fig 11.33).

Solution Since the distance from the focus to the vertex is 5 cm. We have, $a = 5$. If the origin is taken at the vertex and the axis of the mirror lies along the positive x -axis, the equation of the parabolic section is

$$y^2 = 4(5)x = 20x$$

Note that $x = 45$. Thus

$$y^2 = 900$$

Therefore $y = \pm 30$

Hence $AB = 2y = 2 \times 30 = 60$ cm.

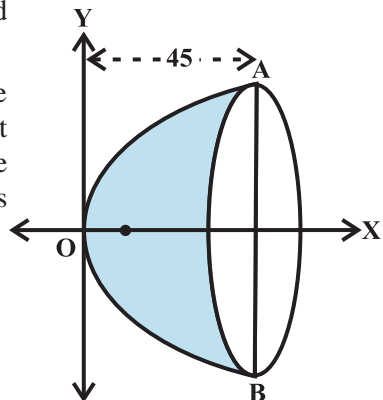

Fig 11.33

Example 18 A beam is supported at its ends by supports which are 12 metres apart. Since the load is concentrated at its centre, there

is a deflection of 3 cm at the centre and the deflected beam is in the shape of a parabola. How far from the centre is the deflection 1 cm?

Solution Let the vertex be at the lowest point and the axis vertical. Let the coordinate axis be chosen as shown in Fig 11.34.

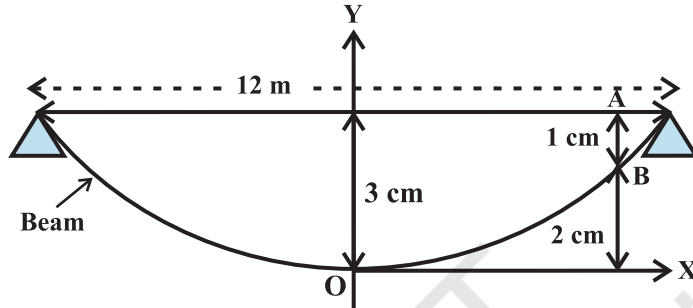

Fig 11.34

The equation of the parabola takes the form $x^2 = 4ay$. Since it passes through $\left(6, \frac{3}{100}\right)$, we have $(6)^2 = 4a\left(\frac{3}{100}\right)$, i.e., $a = \frac{36 \times 100}{12} = 300$ m

Let AB be the deflection of the beam which is $\frac{1}{100}$ m. Coordinates of B are $\left(x, \frac{2}{100}\right)$.

Therefore
$$x^2 = 4 \times 300 \times \frac{2}{100} = 24$$

i.e.
$$x = \sqrt{24} = 2\sqrt{6} \text{ metres}$$

Example 19 A rod AB of length 15 cm rests in between two coordinate axes in such a way that the end point A lies on x-axis and end point B lies on y-axis. A point P(x, y) is taken on the rod in such a way that AP = 6 cm. Show that the locus of P is an ellipse.

Solution Let AB be the rod making an angle θ with OX as shown in Fig 11.35 and P(x, y) the point on it such that AP = 6 cm.

Since AB = 15 cm, we have

$$PB = 9 \text{ cm.}$$

From P draw PQ and PR perpendiculars on y-axis and x-axis, respectively.

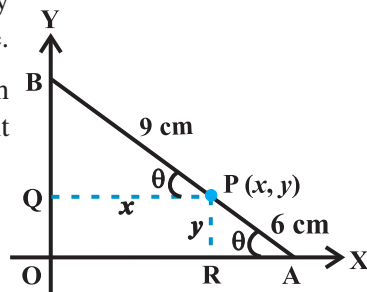

Fig 11.35

From ΔPBQ , $\cos \theta = \frac{x}{9}$

From ΔPRA , $\sin \theta = \frac{y}{6}$

Since $\cos^2 \theta + \sin^2 \theta = 1$

$$\left(\frac{x}{9}\right)^2 + \left(\frac{y}{6}\right)^2 = 1$$

or $\frac{x^2}{81} + \frac{y^2}{36} = 1$

Thus the locus of P is an ellipse.

Miscellaneous Exercise on Chapter 11

1. If a parabolic reflector is 20 cm in diameter and 5 cm deep, find the focus.
2. An arch is in the form of a parabola with its axis vertical. The arch is 10 m high and 5 m wide at the base. How wide is it 2 m from the vertex of the parabola?
3. The cable of a uniformly loaded suspension bridge hangs in the form of a parabola. The roadway which is horizontal and 100 m long is supported by vertical wires attached to the cable, the longest wire being 30 m and the shortest being 6 m. Find the length of a supporting wire attached to the roadway 18 m from the middle.
4. An arch is in the form of a semi-ellipse. It is 8 m wide and 2 m high at the centre. Find the height of the arch at a point 1.5 m from one end.
5. A rod of length 12 cm moves with its ends always touching the coordinate axes. Determine the equation of the locus of a point P on the rod, which is 3 cm from the end in contact with the x -axis.
6. Find the area of the triangle formed by the lines joining the vertex of the parabola $x^2 = 12y$ to the ends of its latus rectum.
7. A man running a racecourse notes that the sum of the distances from the two flag posts from him is always 10 m and the distance between the flag posts is 8 m. Find the equation of the posts traced by the man.
8. An equilateral triangle is inscribed in the parabola $y^2 = 4ax$, where one vertex is at the vertex of the parabola. Find the length of the side of the triangle.

Summary

In this Chapter the following concepts and generalisations are studied.

- ◆ A circle is the set of all points in a plane that are equidistant from a fixed point in the plane.

- ◆ The equation of a circle with centre (h, k) and the radius r is

$$(x - h)^2 + (y - k)^2 = r^2.$$

- ◆ A parabola is the set of all points in a plane that are equidistant from a fixed line and a fixed point in the plane.

- ◆ The equation of the parabola with focus at $(a, 0)$ $a > 0$ and directrix $x = -a$ is

$$y^2 = 4ax.$$

- ◆ Latus rectum of a parabola is a line segment perpendicular to the axis of the parabola, through the focus and whose end points lie on the parabola.

- ◆ Length of the latus rectum of the parabola $y^2 = 4ax$ is $4a$.

- ◆ An *ellipse* is the set of all points in a plane, the sum of whose distances from two fixed points in the plane is a constant.

- ◆ The equation of an ellipse with foci on the x -axis is $\frac{x^2}{a^2} + \frac{y^2}{b^2} = 1$.

- ◆ Latus rectum of an ellipse is a line segment perpendicular to the major axis through any of the foci and whose end points lie on the ellipse.

- ◆ Length of the latus rectum of the ellipse $\frac{x^2}{a^2} + \frac{y^2}{b^2} = 1$ is $\frac{2b^2}{a}$.

- ◆ The eccentricity of an ellipse is the ratio between the distances from the centre of the ellipse to one of the foci and to one of the vertices of the ellipse.

- ◆ A *hyperbola* is the set of all points in a plane, the difference of whose distances from two fixed points in the plane is a constant.

- ◆ The equation of a hyperbola with foci on the x -axis is : $\frac{x^2}{a^2} - \frac{y^2}{b^2} = 1$

◆ Latus rectum of hyperbola is a line segment perpendicular to the transverse axis through any of the foci and whose end points lie on the hyperbola.

◆ Length of the latus rectum of the hyperbola : $\frac{x^2}{a^2} - \frac{y^2}{b^2} = 1$ is : $\frac{2b^2}{a}$.

◆ The eccentricity of a hyperbola is the ratio of the distances from the centre of the hyperbola to one of the foci and to one of the vertices of the hyperbola.

Historical Note

Geometry is one of the most ancient branches of mathematics. The Greek geometers investigated the properties of many curves that have theoretical and practical importance. Euclid wrote his treatise on geometry around 300 B.C. He was the first who organised the geometric figures based on certain axioms suggested by physical considerations. Geometry as initially studied by the ancient Indians and Greeks, who made essentially no use of the process of algebra. The synthetic approach to the subject of geometry as given by Euclid and in *Sulbasutras*, etc., was continued for some 1300 years. In the 200 B.C., Apollonius wrote a book called '*The Conic*' which was all about conic sections with many important discoveries that have remained unsurpassed for eighteen centuries.

Modern analytic geometry is called '*Cartesian*' after the name of Rene Descartes (1596-1650) whose relevant '*La Geometrie*' was published in 1637. But the fundamental principle and method of analytical geometry were already discovered by Pierre de Fermat (1601-1665). Unfortunately, Fermat's treatise on the subject, entitled *Ad Locus Planos et Solidos Isagoge* (Introduction to Plane and Solid Loci) was published only posthumously in 1679. So, Descartes came to be regarded as the unique inventor of the analytical geometry.

Isaac Barrow avoided using cartesian method. Newton used method of undetermined coefficients to find equations of curves. He used several types of coordinates including polar and bipolar. Leibnitz used the terms '*abscissa*', '*ordinate*' and '*coordinate*'. L'Hospital (about 1700) wrote an important textbook on analytical geometry.

Clairaut (1729) was the first to give the distance formula although in clumsy form. He also gave the intercept form of the linear equation. Cramer (1750)

made formal use of the two axes and gave the equation of a circle as

$$(y - a)^2 + (b - x)^2 = r$$

He gave the best exposition of the analytical geometry of his time. Monge (1781) gave the modern ‘point-slope’ form of equation of a line as

$$y - y' = a (x - x')$$

and the condition of perpendicularity of two lines as $aa' + 1 = 0$.

S.F. Lacroix (1765–1843) was a prolific textbook writer, but his contributions to analytical geometry are found scattered. He gave the ‘two-point’ form of equation of a line as

$$y - \beta = \frac{\beta' - \beta}{\alpha' - \alpha} (x - \alpha)$$

and the length of the perpendicular from (α, β) on $y = ax + b$ as $\frac{(\beta - a - b)}{\sqrt{1 + a^2}}$.

His formula for finding angle between two lines was $\tan \theta = \left(\frac{a' - a}{1 + aa'} \right)$. It is, of

course, surprising that one has to wait for more than 150 years after the invention of analytical geometry before finding such essential basic formula. In 1818, C. Lamé, a civil engineer, gave $mE + m'E' = 0$ as the curve passing through the points of intersection of two loci $E = 0$ and $E' = 0$.

Many important discoveries, both in Mathematics and Science, have been linked to the conic sections. The Greeks particularly Archimedes (287–212 B.C.) and Apollonius (200 B.C.) studied conic sections for their own beauty. These curves are important tools for present day exploration of outer space and also for research into behaviour of atomic particles.

